

Use of External Fluid Property Code in Modelica for Modelling of a Pre-combustion CO₂ Capture Process Involving Multi-Component, Two-Phase Fluids

Carsten Trapp^{*1}, Francesco Casella², Teus van der Stelt¹ and Piero Colonna¹

¹*Delft University of Technology, Propulsion and Power, Kluyverweg 1, 2629 HS Delft, The Netherlands*

²*Politecnico di Milano, Dipartimento di Elettronica, Informazione e Bioingegneria, Via Ponzio 34/5, 20133 Milano, Italy*

Pre-combustion CO₂ capture applied to integrated gasification combined cycle (IGCC) power plants is a promising technical solution to mitigate CO₂ emissions and therefore the effect of climate change. The integration of the CO₂ removal unit with the very complex gasification process and combined cycle power plant leads to challenges especially regarding dynamic operation, which nowadays becomes increasingly important as the share of electricity produced by renewable energy sources, which is inherently unsteady, is continuously growing.

This paper presents the development of a system model for a pre-combustion CO₂ capture process in order to study process transient performance during load variations. The models have been validated by comparison with experimental data obtained from a unique, fully instrumented CO₂ capture pilot plant, which has been realized at the Buggenum IGCC power station in the Netherlands by the utility company Vattenfall.

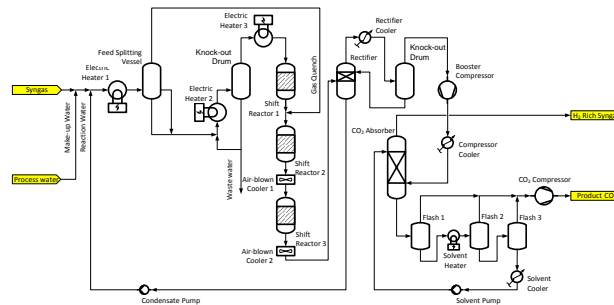

Figure 1: Process flow diagram CO₂ capture pilot plant.

The main challenge of the model development is related to the computation of fluid properties, in particular phase equilibria, due to the fact that highly non-ideal, two-phase, multi-component fluids are involved in the capture process, which are currently not supported by available Modelica media libraries or interfaces.

Therefore, an interface prototype was developed and tested with the fluid property package FluidProp for the modelling and simulation of the CO₂ capture process. Due to limitations regarding index reduction if using external property functions, an approach on how to develop index-1 models and choose system state variables as well as thermodynamic states appropriately is discussed. Furthermore, various ideas in order to improve computational efficiency, when expensive phase equilibria calculations are involved, are presented. Recommendations about the design of a library for the use of external property estimation code in Modelica conclude the treatment.

^{*}Email: C.Trapp@tudelft.nl, P.Colonna@tudelft.nl