

Dynamic modelling of a parabolic trough solar power plant

Robert Österholm^a, Jens Pålsson^b

^aLund University, LTH, Department of Energy Sciences, Lund, Sweden

^bModelon AB, Ideon Science Park, Lund, Sweden

osterholm.r@gmail.com, jens.palsson@modelon.com

Abstract

Models for dynamic simulation of a parabolic trough concentrating solar power (CSP) plant were developed in Modelica for the simulation software tool Dymola. The parabolic trough power plant has a two-tank indirect thermal storage with solar salt for the ability to dispatch electric power during hours when little or no solar irradiation is present. The complete system consists of models for incoming solar irradiation, a parabolic trough collector field, thermal storage and a simplified Rankine cycle. In this work, a parabolic trough power plant named Andasol located in Aldeire y La Calahorra, Spain is chosen as a reference system. The system model is later compared against performance data from this reference system in order to verify model implementation. Test cases with variation in solar insolation reflecting different seasons is set up and simulated. The tests show that the system model works as expected but lack some of the dynamics present in a real thermal power plant. This is due to the use of a simplified Rankine cycle. The collector and solar models are also verified against literature regarding performance and show good agreement.

Keywords: concentrating solar power; parabolic trough; solar salt thermal storage; dynamic modeling; Dymola; Modelica.

1 Introduction

Thermal solar power is a technology of which the solar irradiation on earth is harvested in order to produce power in the range of village type application of several kilowatts all the way up to grid connected power plants producing several hundred Megawatts. It is an environmentally friendly way of producing power not contributing to the rising amount of greenhouse gases and other hazardous particles that

are let out in the atmosphere by traditional fossil fired power plants.

The principle is to concentrate the solar irradiation using a configuration of mirrors to produce high temperature heat. The heat is then transported to a boiler where steam is produced for a steam turbine or the heat can be used to power a heat engine. A generator coupled with the turbine or heat engine is then producing electrical power. Some systems also have the capability to store heat for use during for instance cloudy days and at night. There is a range of different configurations available both in the way solar irradiation is concentrated and how the produced heat is used to generate power. The most common, in regards of development and number of units built, thermal solar power plants will be presented.

A thermal solar power plant can be divided into three subsystems consisting of the collector, the thermal storage and the power cycle. Another important aspect of the system is the medium that is used to transport heat from the collector field to the power cycle and the medium used for thermal storage. The different characteristics and the most common medium used in a typical thermal concentrating solar power plant will be presented.

1.1 Collector

The concentrating device of a thermal solar power plant consists of mirrors, the collector, focusing the incoming solar irradiation on to a heat-absorbing device, the receiver. This is done because the solar irradiation per square meter on earth is too small to heat anything to a desired temperature used in power generating applications. By concentrating the irradiation from a large area on to a small point high temperatures can be reached [1]. The arrangement of the mirrors differs depending on which type of CSP plant configuration that is used.

Most mirror configurations use a tracking system to follow the movement of the sun in the sky in order to maximize the heat collection throughout the day. This can be done with either one (east-west direction) or two axes (additionally north-south direction). Systems using one axis require less investment and maintenance cost at somewhat lower performance compared to two-axis tracking system.

1.2 Thermal storage

Thermal storage capability is the key to cost efficient and flexible CSP plant operation. With thermal storage the plant owner is able to dispatch power when it's most valuable which often is in the evening when there is low or little incoming solar irradiation and the electricity price is high. There are a number of thermal storage solutions that are both in operation and under development. The type that has gained the most attention in recent years is a system where heat is stored in molten nitrate. Other types use rock, sand and oil as storage media [2].

1.3 Power cycle

Most currently operating solar trough and power tower systems use a Rankine cycle for electricity production. Water is heated up in a boiler producing high-pressure steam that is fed into a steam turbine coupled to a generator. Temperature and pressure data depends on the turbine design and heat source. In CSP plant applications the thermal fluid medium reaches a temperature of 400 to 600 °C. This means that steam temperature of around 350 to 550 °C and a pressure of 100 bar is common. Some CSP plants use a heat engine (such as Stirling motor or Brayton cycle) to produce power. Most solar plants are located in sunny and dry climate and use an air cooled condenser instead of the more common use of water as cooling medium [3].

1.4 Thermal media

Different heat absorbing fluids are used in CSP plants operated today. The fluid is often mentioned the thermal heating fluid or just "THF" and is used to transport heat from the concentrating apparatus to the power cycle. Some systems that use a heat engine don't use any thermal heating fluid. The most common type of THF is a thermal oil that can be heated up to around 400 °C. There are also systems that use molten salt mixture which can be heated to around 500 °C, but need an advanced control system to prevent the salt to crystallize at around 200 °C. [4] [5].

2 Parabolic trough and other concentrating solar power technologies

In the parabolic trough type CSP plant the solar irradiation is concentrated by parabolic curved, trough-shaped reflectors onto a receiver pipe running along the inside of the curved surface. The medium in the receiver pipes is heated by the concentrated solar energy and used to produce steam in a Rankine cycle. The mirrors are typically placed in parallel rows along a north to south axis to be aligned towards the sun. A tracking system angles the mirrors to minimize the incidence angle from the solar beams. Trough systems can incorporate thermal storage. Many currently operating systems are hybrids meaning they can be supplementary fired with an alternative fuel (often natural gas) when the solar irradiation and heat storage is not enough to run the plant. A typical parabolic trough plant can produce 50 MW to 100 MW of electrical power. One of the largest operating CSP plants today, the Shams 1, is of parabolic trough type. It has a power output of 100 MW and is located in the Abu Dhabi Emirate. [4] [5]

The linear Fresnel system works in the same way as the parabolic trough with another collector and mirror design. The absorber is elevated with several mirrors mounted under the absorber tube. A separate tracking device gives the mirrors high flexibility to track the movement of the sun. This system has a lower investment and operation cost than the parabolic trough system. The major disadvantage is the lower solar to electricity efficiency [8].

Power tower systems use one central receiver mounted on top of a tower. A large amount mirrors, so called heliostats, are placed around the tower and track the sun in two axes. The THF is heated to rather high temperature and is used to produce steam in a Rankine cycle. Recently molten nitrate has been introduced which is also the most common medium used in the thermal storage, eliminating the need for a heat exchanger between the thermal heating fluid and the thermal storage fluid [6].

The parabolic dish system utilizes a large two axis parabolic mirror concentrating the incoming irradiation on to a receiver in the mirror focal point. The receiver is typically a heat powered motor meaning that the absorbed heat is used directly in the receiver to produce electricity. The setup has been realized in plants producing up to 5 MW of electricity.

3 Reference system

The most common and mature technology for thermal solar power is the parabolic trough design with indirect two-tank thermal storage capability [9], and chosen as the subject of this study. In order to model the system correctly regarding incoming solar irradiation a specific location on earth is needed. The Andasol power plant in Aldeire y La Calahorra, Spain, was chosen as reference system because the availability of performance data and plant design parameters. Technical specifications of the Andasol power plant are presented in Table 1 below [11].

Plant name	Andasol-I and Andasol-II
Plant location	Aldeire y La Calahorra, Spain
Plant type	Parabolic trough
Start date	June 1, 2009
Receiver type	Schott PRT-70
Sun tracking	One axis in north-south direction
Collector type	Flabeg RP-3
Thermal heating fluid type	Dowtherm A
Turbine type	Siemens SST-700 50MW steam turbine
Thermal heat storage type	Two-tank indirect with molten solar salt

Table 1 Andasol power plant specification

The thermal heating fluid used in Andasol-I and Andasol-II are of the type Dowtherm A. The system modeled will use another type of THF manufactured by Eastman Chemical Company with product name Therminol VP-1. Therminol is commonly used in concentrating solar power plants today [12]. Also, more technical data is available about the Therminol heat fluid than the Dowtherm type.

4 Modeling the solar power plant

The different system components described in section one will be implemented in Dymola. There are no solar power specific components present in available Modelica libraries today. After model implementation of the components an evaluation will be made against available data. Furthermore, when the different components are working properly they will be connected to a system model that will be compared against performance data given by the operator of the reference system.

4.1 Media models

Both the THF circulated through the receivers and the fluid used in the thermal heat storage need to be implemented in Modelica for use in Dymola. A sim-

plified temperature dependent medium model is developed where thermodynamic state is interpolated from a table. The THF called Therminol is a clear, transparent synthetic oil made of an eutectic mixture of 73.5 % diphenyl oxide and 26.5 % biphenyl. The oil has one of the highest thermal stabilities of all organic heat transfer fluids and is stable in liquid phase between 12 °C and 400 °C. This makes it ideal for use in CSP applications [13].

The fluid used in the thermal heating storage is a mixture of 60 % $NaNO_3$ and 40 % KNO_3 by weight often referred to as solar salt. Solar salt is used because of its thermodynamic properties such as high heat capacity, high density, relatively low cost and low vapor pressure. The low vapor pressure makes the salt storage easy because no pressurized tanks are needed. Another favorable feature of solar salt is the high temperature stability and liquid phase up to 560 °C. The downside is that it has a rather high melting point starting to crystallize at 238 °C. This means that special care must be taken to prevent the salt from freezing causing major damage to pipes, pumps and heat exchangers [14]. The thermodynamic properties of solar salt are implemented in the same way as the THF (Therminol).

4.2 Sun model

A set of different equations is needed to calculate the direct solar irradiation onto a surface, in this case a solar collector assembly, for a specific date, time and location on earth.

The term solar time is used when calculating the angles that are needed to determine how much direct radiation will hit a collector, and differs from the local time on earth. The difference in minutes can be expressed as follows [15]:

$$\text{solar time} - \text{local time} = 4 \cdot (L_{st} - L_{loc}) + E \quad (1)$$

Where L_{st} is the standard meridian for the local time zone, L_{loc} is the longitude of the location in degrees west and E is the equation of time.

Equation of time is expressed as:

$$E = 229.2 \cdot (0.000075 + 0.001868 \cdot \cos B - 0.032077 \cdot \sin B - 0.014615 \cdot \cos 2B - 0.04089 \cdot \sin 2B) \quad (2)$$

Where

$$B = (n - 1) \cdot \frac{360}{365} \quad (3)$$

And n = day of the year [15].

The angle of incidence of direct solar radiation onto a north to south axis tracking collector that is used at the Andasol plant can be calculated as follows [15]:

$$\cos \theta = (\cos \theta_z^2 + \cos^2 \delta^2 \cdot \sin \omega^2)^{0.5} \quad (4)$$

Where δ is the declination, the angular position of the sun at solar noon [15].

$$\delta = 23.45 \cdot \sin\left(360 \frac{284+n}{365}\right) \quad (5)$$

ω is the hour angle, the angular displacement of the sun east or west of the local meridian due to rotation of the earth on its axis at 15° per hour [16].

$$\omega = (t_{sol} - 12) \cdot 15 \quad (6)$$

θ_z is the zenith angle, the angle of incidence of beam radiation on a horizontal surface [15].

$$\theta_z = \cos \phi \cdot \cos \delta \cdot \cos \omega + \sin \phi \cdot \sin \delta \quad (7)$$

Where ϕ is the latitude.

The incidence angle is the angular difference θ between the normal to the aperture and the actual solar irradiation that can be seen in Figure 1. When the direct beam radiation is not normal to the plane of the collector aperture there is a loss of direct beam radiation that scale with the cosines of the angle θ .

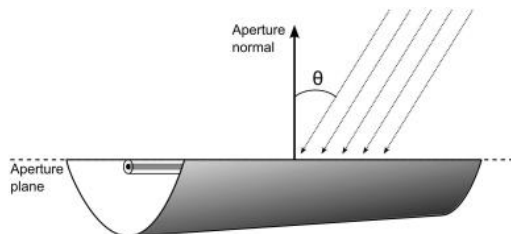

Figure 1 A graphical interpretation of the angle between the aperture normal and the solar irradiation [16].

4.3 Collector model

The collector is a mirror shaped as a half cylindrical parabolic reflector focusing the incoming solar irradiation onto the absorber pipe. There are numerous equations to describe the geometry of the mirror and the image, distribution of solar radiation flux across the focus, it produces. It is assumed that the collector design already is optimized which gives the parameters that should be provided to the collector model in Dymola. The parameters of interest are the optical efficiency and collector aperture width and length.

The aperture width is the trough width and the total aperture area is the length of the collector times the aperture width. The total aperture area gives the total amount of solar irradiation that can be concentrated onto the receiver.

There are several models for the mirror loss that have to be taken into account. In this model a single parameter called optical efficiency, η_{opt} , is introduced to describe the total mirror efficiency. The different losses included in this parameter are listed in Table 2 below [16].

Tracking error	Inability of the collector to perfectly orient along the tracking angle. Twisting of the collector about the lengthwise axis.	η_{track}
Geometry defects	Poor alignment of the mirror modules.	η_{geo}
Mirror soiling	Dirt or soiling on the reflective surface that decreases the reflected amount of solar irradiation onto the absorber pipe.	η_{soil}
General error	Any other loss not covered by previous categories.	η_{gen}

Table 2 List of mirror losses.

This gives the optical efficiency:

$$\eta_{opt} = \eta_{track} \cdot \eta_{geo} \cdot \eta_{soil} \cdot \eta_{gen} \quad (8)$$

This efficiency term is multiplied with the total radiation incidence on the collector calculated earlier in the sun model and the total aperture area which gives the amount of incoming, reflected solar irradiation onto the receiver.

$$\dot{Q}_{receiver} = I_{field} \cdot A_{tot,aperture} \cdot \eta_{opt} \quad [W] \quad (9)$$

4.4 Receiver model

The amount of heat absorbed by the THF in the receiver model considers the amount lost due to radiation and convection to the surroundings. The radiation and convection losses, either natural in case in no wind or forced in case of wind, are heat transferred from the outer glass envelope of the receiver. Because of the long receiver length, in the Andasol case almost 90000 m, the temperature and heat losses will vary along the absorber axis. In this case the model is discretized i.e. the absorber pipe is divided in n number of segments. The heat transfer equations are then solved in each segment summing up to the total heat transfer. By doing this a much more accurate model is obtained as discussed in several studies on the subject [17]. The receiver can be represented as a thermal resistant network as shown in Figure 3. The temperatures denoted in the equations that follow are marked in Figure 2 and Figure 3.

The absorbed energy in the receiver pipe is modeled with a standard conduction heat transfer model for a metal wall already available in Modelon Base Library (MBL). It is assumed that the pipe is made out of standard carbon steel. The heat transferred through the metal wall is then absorbed by the THF by convection in a pipe model also already available in MBL.

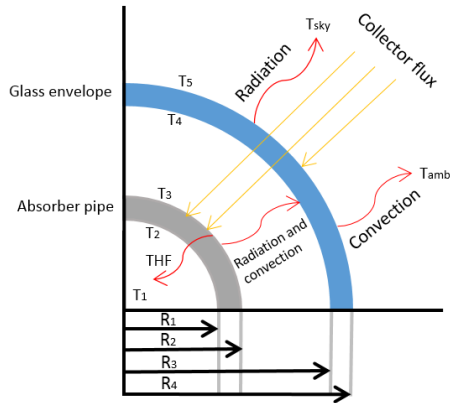

Figure 2 Measurements and heat flow in receiver.

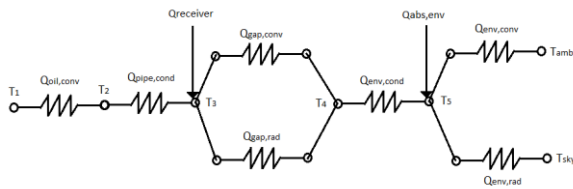

Figure 3 Receiver model represented as a thermal resistance network.

The outer surface in commercial absorbers is coated with special materials to decrease reflection from the surface. In the parameter settings for the receiver the surface emissivity of the pipe can be set to a value representing the current coating material.

From the pipe surface both convection and radiation occurs in the vacuum gap between the outer glass envelope and the pipe. The convection is modeled with a standard convective heat transfer model developed by Modelon. When this gap is under vacuum the convective heat transfer mechanism is molecular conduction between molecules. If the vacuum is lost for example by a crack in the glass cover the heat transfer mechanism is free convection [18]. It is assumed that vacuum is always present in the gap for this model and that the heat transfer coefficient for the vacuum of air is $k_{c,gap} = 0.0001115 \text{ W/m}^2\text{K}$ [17]. The heat transfer coefficient is provided as a model parameter for the user which means that simulations with different vacuum properties or vacuum with different gases other than air can be made.

$$\dot{Q}_{gap,conv} = k_{c,gap} \cdot D_3 \cdot \pi \cdot L_{rec} \cdot (T_3 - T_4) \quad (10)$$

There were no models for radiation present in any Modelica library which had to be developed and based on following expressions:

$$\dot{Q}_{gap,rad} = \pi \cdot D_3 \cdot L_{rec} \cdot \gamma_{gap,rad} \cdot (T_3 - T_4) \quad (11)$$

$$\gamma_{gap,rad} = \sigma \cdot (T_3^2 - T_4^2) \cdot \frac{T_3 + T_4}{\frac{1}{\epsilon_3} + \frac{D_3}{D_4} \cdot \left(\frac{1}{\epsilon_4} - 1\right)} \quad (12)$$

Several assumptions were made in deriving this equation but the errors caused are relatively small [17]. The glass envelope is implemented as a heat transfer model including wall material with constant parameters developed by Modelon. The user needs to provide data for the glass material such as density, specific heat capacity and thermal conductivity. Most receiver glass envelopes are made out of borosilicate glass that has a very low coefficient of thermal expansion. This makes them resistant to thermal shock that is crucial in CSP applications [23].

Most of the solar irradiation concentrated onto the receiver is utilized by the THF but the receiver glass envelope also absorbs some heat. This raises the glass surface temperature and creates a temperature difference to the ambient. The amount of heat absorbed by the glass can be expressed as follows [19]:

$$\dot{Q}_{env,abs} = \dot{Q}_{receiver} \cdot \frac{\alpha_{env}}{\tau_{env} \cdot \alpha_{abs}} \quad (13)$$

Some of the heat transferred through the glass envelope is lost by radiation due to temperature differences between the glass and the sky. Convective heat transfer also occurs and is either natural or forced depending on if there is wind or not.

The radiation loss can be expressed as follows when assuming the glass envelope to be a small convex gray body surrounded by a large black body that represents the sky [17]:

$$\dot{Q}_{env,rad} = \sigma \cdot \pi \cdot D_4 \cdot L_{rec} \cdot (T_5^4 - T_{sky}^4) \quad (14)$$

The sky temperature can be assumed to be 8 degrees lower than the ambient temperature [20].

The convection from the outer surface of the glass envelope can be expressed as follows:

$$\dot{Q}_{env,conv} = h_{amb} \cdot \pi \cdot D_4 \cdot L_{rec} \cdot (T_5 - T_{amb}) \quad (15)$$

Where h_{amb} is the convective heat transfer coefficient to ambient.

For natural convection (no wind) the heat transfer function can be expressed as follows [17]:

$$h_{amb,nowind} = \overline{Nu} \cdot \frac{k_{56}}{D_4} \quad (16)$$

Where the Nusselt number can be calculated using a correlation developed by Churchill and Chu for a long isothermal horizontal cylinder [17].

All thermodynamic properties are calculated at the mean temperature between the envelope surface and the ambient temperature $T_{56} = \frac{T_5 + T_{amb}}{2}$

Forced convection heat transfer will occur at windy conditions and is calculated in the same way as for natural convection but the Nusselt number will instead be estimated with Zhukauskas' correlation for external forced convection flow normal to an isothermal cylinder as follows from [17].

When the heat loss by radiation and convection from the envelope is known, and the same for the vacuum gap, the amount of heat absorbed by the thermal heating fluid is known:

$$\dot{Q}_{oil,conv} = \dot{Q}_{absorber} - \dot{Q}_{gap,rad} - \dot{Q}_{gap,conv} \quad (17)$$

$$\dot{Q}_{gap,rad} + \dot{Q}_{gap,conv} = \dot{Q}_{env,rad} + \dot{Q}_{env,conv} - \dot{Q}_{env,abs} \quad (18)$$

4.5 Thermal storage model

The thermal storage task is to supply extra heat to the plant when the solar irradiation is below a certain value. In this case the outlet temperature of the THF from the collector field cannot reach the desired value of 393 °C, the design point temperature for the Andasol power plant. This is when the thermal storage instead is used heating the thermal heating fluid to 373 °C. It is not possible to reach the design point temperature because of losses in the heat exchanger between the thermal oil and the solar salt.

The collector field for the Andasol power plant is over-sized in order to be able to produce heat for both charging the thermal storage and the power cycle during the whole day and not only when the insolation is peaking in the middle of the day. With no thermal storage the collector field size could be reduced with approximately 40 %. After a couple of hours when the thermal storage is completely charged too much heat is absorbed just for the power cycle and a part of the collector field is intentionally defocused [20].

The heat from the THF is transferred to the solar salt via a heat exchanger with a 10 °C pinch point. When the solar salt is used to heat up the THF the system is reversed and the thermal fluid is heated up via the same heat exchanger. The THF will then reach an outlet temperature 10 °C below the solar salt inlet temperature. It is assumed that the thermal storage tanks are well insulated and no heat loss occurs.

The charging of the solar salt is made by tapping off a part of the heated THF from the collector field and redirecting this to the heat exchanger between the thermal oil and the solar salt. The mass flow rate of the thermal fluid through the heat exchanger is given by a simple energy balance and the fact that the minimum mass flow rate to the power cycle is known.

The discharging of heat from the thermal storage is a bit more complicated. The collector field is shut off via valves creating a new loop for the THF that runs through the thermal storage and then directly to the power cycle. This isolates the main THF pump creating the need for a secondary pump which is only used when discharging the thermal storage. The mass flow rate of this pump is calculated for the power cycle THF inlet temperature of 373 °C. The user can set the threshold value of incoming solar irradiation, the minimum amount of incoming solar irradiation where the system switches to run on the thermal storage. Under all simulations in this paper the value of 400 W/m² is used which means that the system will switch over to run on the thermal storage when the DNI is less than this value. The value has been chosen after testing the model and is not calculated.

4.6 Rankine cycle model

The power cycle including boiler, steam turbine, generator and condenser is simply modeled. The Rankine power cycle model consists of a single heat exchanger where the THF flows on the primary side and the water boiled to steam on the secondary side. The water is supplied from a source and dumped in a sink meaning that there are no models for turbine, generator or condenser. By using this approach the thermal inertia of the otherwise big boiler is not accounted for. This means that the system modeled in Dymola will react too fast to changes in incoming thermal fluid temperature.

5 Modelica implementation

The Modelica language for dynamic simulations is ideal for CSP applications. The solar irradiation equations are time dependent and easily calculated after implementation in Modelica. There are different plant operating modes depending on solar insolation, amount of heat stored in the thermal storage and other events that has to be taken into account when the plant is simulated. There are also several modes the plant has to switch between in order to produce optimal amount of electricity to the grid. This kind of dynamics combined with automatic control, which Modelica is well suited for, makes it possible to test and simulate plant performance and behavior in a fine resolution. The downside with Modelica is a rather high threshold for new users.

The system model consists of Modelica implementation of the main components described and connecting them using system controller, see Figure 4.

- Sun model based on 15-minutes time series weather data on a file from a location close to Andasol plant in Spain
- Collector model consisting of own implementations of heat resistance and mirror models, and base classes (pipe and wall models) from Liquid Cooling Library (LCL) and Thermal Power Library (TPL)
- Thermal heat storage model implemented with own models combined with efficiency based heat exchanger model from MBL
- Simplified Rankine cycle solely consisting of source and sink terms and the same base class heat exchanger model from MBL
- Additionally a pump like component from LCL (setFlowRate) and an expansion volume component from MBL used for the thermal oil circuit.
- Thermal heating fluid (Therminol) implemented as table based media template class from LCL
- System controller for controlling mainly thermal heat storage as well as flow rate in the thermal oil and Rankine cycle circuits
- A summary record for key parameters and results

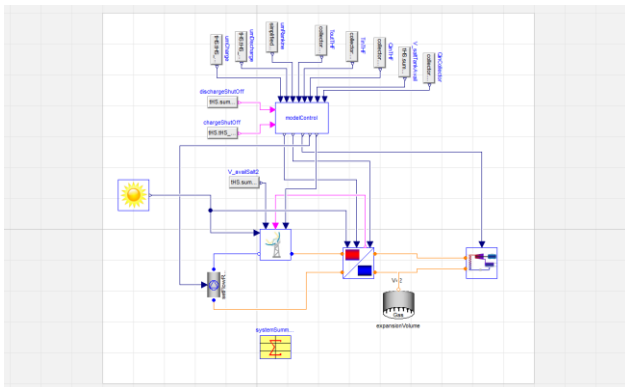

Figure 4 System model as in the Dymola Modeling view

6 Verification of system model

To verify the system performance a comparison with the Andasol I parabolic trough power plant is carried out with the same design parameters provided by the plant operator [22]. The goal is to match efficiencies from different parts of the system with them from the Andasol power plant. The thermal storage will not be used in this test, neither for heating up the salt nor to heat up the thermal fluid. They are left out from the simulation due to efficiency calculations that will turn out wrong if heat is added or subtracted from the

system. The performance numbers given by Andasol are based on an average typical weather year. To match the incoming solar irradiation a median value of the yearly incoming solar irradiation for a typical meteorological year were used as input to the system model and the specific simulation day was set to day no. 92 and the time to 10 AM. This represents a median value of the solar position.

Efficiency	Andasol	System model
Solar field – solar irradiance to steam	43 %	42.6 %
Rankine – steam to electricity	38.8 %	38.8 %
System – solar irradiance to electricity	16 %	16.5 %

Table 3 Results from system model validation.

As shown in Table 3 the values from the system model align well with plant data indicating a correct implementation of the system model. However, the Rankine efficiency is the whole cycle efficiency but in the system model only a simplified Rankine cycle is used. Therefore the same efficiency provided by Andasol was used to calculate the amount of electricity produced by the system model.

7 Results from test cases

In this section two different simulations from a clear and a partly clouded summer day respectively will be shown. By studying the behavior of the system model under these conditions, understanding of how the system handles solar irradiation variations can be gained. Information about system performance during a single day and how the system handles low values of solar insolation can also be obtained.

7.1 Simulation of a typical clear summer day

Flabeg, the manufacturer of the solar collector assemblies for the Andasol power plant is demonstrating the performance of the plant for a typical clear summer day in Figure 5. This figure serves as a benchmark and gives a hint of how the system model in Dymola should behave under similar conditions. The system model is set up to run on day 189 i.e. 8th of July, with the simulation starting at 4 AM and running for 24 hours. The results are presented in Figure 6 below.

As can be seen the simulation in Dymola is a bit more irregular than the presented graph from Flabeg, for instance some very sharp curves. The most obvious reason for this is that the graph of Figure 5 is a computer rendering and not based on actual calculations, which is the case for the other graphs.

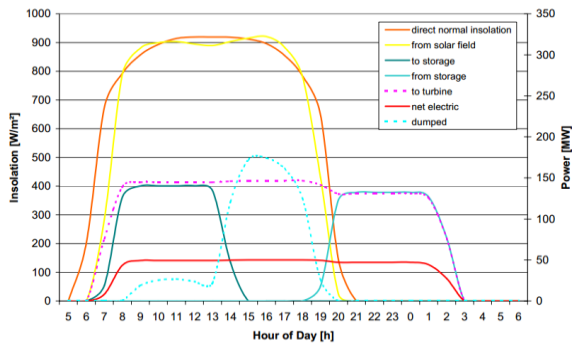

Figure 5 Insolation and heat flow to and from different system parts of the Andasol power plant [21].

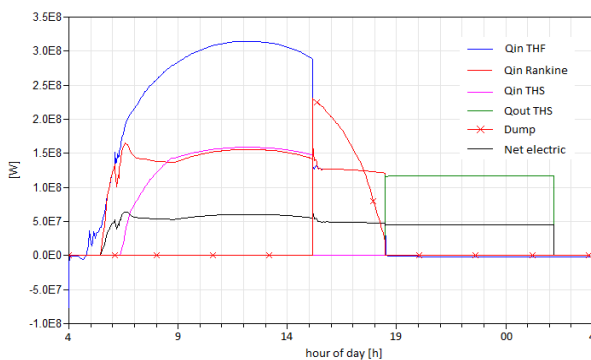

Figure 6 Heat flow to and from different system parts in the system model in Dymola.

There is a problem with the automatic control circuit causing the fluctuations in the beginning of the simulation in Figure 6. This could be avoided if the control parameters were to be optimized.

7.2 Partly clouded typical summer day

How the system behaves during a day which is partly clouded is investigated next with a custom set of solar data parsed to the system based on the data from the typical clear summer day, day no. 189. The incoming solar irradiation during the simulation is shown in Figure 7. The sudden drop in incoming solar irradiation is supposed to mimic a big cloud moving over the solar power plant. After three hours the cloud has passed and the solar irradiation goes back up again until the end of the day. The system results are shown in Figure 8.

At first the system behaves as in the clear summer day case shown in Figure 6 but when the sun is blocked by the cloud the thermal storage starts to discharge heat and the power plant can continue deliver power to the grid.

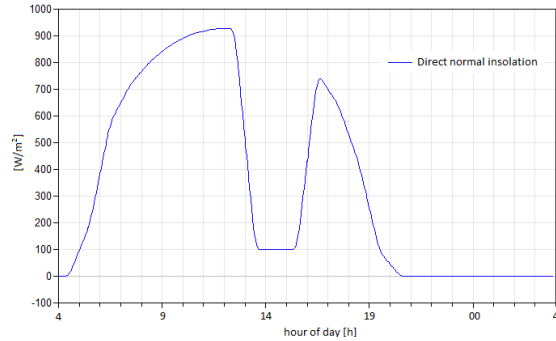

Figure 7 Direct normal insolation for the partly clouded day simulation.

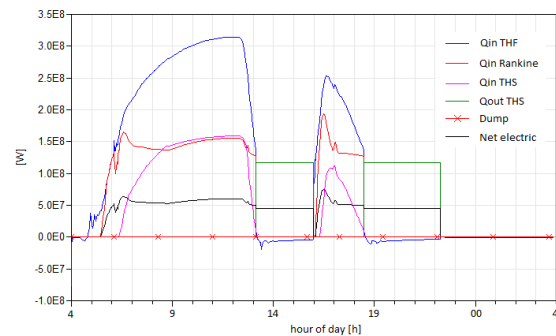

Figure 8 Heat flow from and to different system parts for the partly clouded day simulation in Dymola.

When the cloud passes three hours later the system switches back to run on heated thermal oil from the collector field until the sun sets. Because of the blocking of the sun the thermal storage is not fully charged when the irradiation disappears and the system can only run on the thermal storage for just little under four hours. Another control strategy may be desirable in this case depending on the price fluctuation of electricity. If the price is higher in the evening, which it usually is, the system should not start to discharge heat from the thermal storage during the day. Instead the power cycle could be shut off or put at low load during these hours. The power cycle could then go back up and deliver maximum electrical power in the evening while utilizing the energy contained in the thermal storage.

8 Discussion

The goal with this paper was to successfully model and simulate a concentrating solar power plant of a parabolic trough type and compare results with data found in literature. Parabolic trough is the most common technology with a huge potential to deliver large amount of environmental friendly electricity.

In order to model other types of CSP plants the current models may be redesigned rather easily for a linear Fresnel system. However, this is not the case for the central receiver solar tower design and the parabolic dish type.

The simulation results (numbers) presented may not be very useful in its current form but the models developed can be used for research and future plant analysis and development. There is some old code already existing for dynamic simulations of parabolic trough plants in other simulation tools. These tools do not offer as high degree of flexibility as the models developed for Dymola. The Modelica models can easily be altered and customized for a specific plant design and shortens the project lead time in the design and verification project phases where simulation is important. If systems can be modeled with a high degree of accuracy the time from project start to plant startup can be shortened and the plant performance predicted on an early stage. New system design can be tested and evaluated in an early stage in Dymola and less physical prototype tests have to be done which is much more cost effective and leads to cheaper plant development cost.

The verification done on the solar and collector models and on the system model as a whole, shows good results, which is an indicator that a correct implementation of the loss models has been made. The collector and sun models are considered to be implemented adequately but the thermal storage model needs more work because of the simplifications.

No complete Rankine cycle was implemented which is a drawback but the overall results presented show strong similarities with manufacturer data.

The fast switching between modes, charging and discharging of the thermal storage, and certain irregular behavior could be avoided with better automatic control with parameters optimized for each simulation depending on how much solar irradiation hits the collector during the day. The effects of this dynamics have to be studied more carefully to gain knowledge of which control parameters to modify.

9 References

- [1] P. Menna och D. Rossetti, "Concentrating solar power - from research to implementation," Office for official Publications of the European Communities, Luxembourg, 2007.
- [2] W. Stine och M. Geyer, "Chapter 11 - Energy storage," 29 10 2013. [Online]. Available: <http://www.powerfromthesun.net/Book/chapter11/chapter11.html>.
- [3] W. Stine och M. Geyer, "Chapter 12 - Power Cycles for Electricity Generation," 29 10 2013. [Online]. Available: <http://www.powerfromthesun.net/Book/chapter12/chapter12.html>.
- [4] "Shams 1 factsheet," 29 10 2013. [Online]. Available: <http://www.shamspower.ae/resources/media/Factsheet-ShamsFlyerEnglish.pdf>.
- [5] "Technology Characterization Solar Parabolic Trough," 29 10 2013. [Online]. Available: http://www.solarpaces.org/CSP_Technology/docs/solar_trough.pdf.
- [6] "Technology Characterization Solar Power Towers," 29 10 2013. [Online]. Available: http://www.solarpaces.org/CSP_Technology/docs/solar_tower.pdf.
- [7] "Technology Characterization Solar Dish Systems," 29 10 2013. [Online]. Available: http://www.solarpaces.org/CSP_Technology/docs/solar_dish.pdf.
- [8] M. Gunther, "Linear Fresnel Technology," i *Advanced CSP Teaching Materials*, Enermena;Deutsches Zentrum fur Luft- und Raumfahrt.
- [9] "Concentrating Solar Power Projects by Country," 29 10 2013. [Online]. Available: http://www.nrel.gov/csp/solarpaces/by_country.cf.
- [10] "Gemasolar plant description," 06 06 2010. [Online]. Available: <http://www.torresolenergy.com/TORRESOL/gemasolar-plant/en>. [Använd 29 10 2013].
- [11] "Andasol-2," 29 10 2013. [Online]. Available: http://www.nrel.gov/csp/solarpaces/project_detail.cfm/projectID=4.
- [12] "Parabolic Trough Projects," 29 10 2013. [Online]. Available: http://www.nrel.gov/csp/solarpaces/parabolic_trough.cfm.
- [13] Eastman Chemical Company, "Therminol VP-1 product description," 28 10 2013. [Online]. Available: <http://www.therminol.com/pages/products/vp-1.asp>.
- [14] T. Bauer och N. Breidenbach, "Overview of molten salt storage systems and material development for solar thermal power plants," DLR, Köln,Germany.
- [15] J. A. Duffie and W. A. Beckman, *Solar engineering of thermal processes*, Second

Edition, Madison, Wisconsin: John Wiley & Sons, 1991.

- [16] J. M. Wagner och P. Gilan, "Technical manual for the SAM physical trough model," National Renewable Energy Laboratory, Colorado, 2011.
- [17] R. Forristall, "Heat transfer analysis and modeling of a parabolic trough solar receiver implemented in engineering equation solver," National Renewable Energy Laboratory - U.S. Department of Energy, Colorado, 2003.
- [18] Y. Xiong, Y. Wu, C. Ma, K. Traore och Y. Zhang, "Numerical investigation of thermal performance of heat loss of parabolic trough receiver," *Science China*, pp. 444-452, 5 February 2010.
- [19] F. Burkholder och C. Kutscher, "Heat loss testing of Schott's 2008 PTR70 parabolic trough receiver," National Renewable Energy Laboratory, Golden, Colorado, 2009.
- [20] R. Kistner, Interviewee, *Dumping of heat in the Andasol power plant*. [Intervju]. 18 September 2013.
- [21] U. Herrmann, M. Geyer och R. Kistner, "The Andasol Project - workshop on thermal storage for trough power systems," FLABEG Solar International, Germany, 2002.
- [22] A. Cobra, "Andasol 1 Thermo solar energy project information," [Online]. Available: www.estelasolar.eu/fileadmin/ESTELAdocs/document/powerplants/Andasol.pdf. [Använd 30 October 2013]
- [23] Cambridge Glassblowing Company "Borosilicate glass properties" [Online]. Available: <http://www.camglassblowing.co.uk/gproperties.htm>. [Used 30 October 2013]