

Hardware-in-the-Loop (HIL) Simulation with Modelica - A Design Tool for Thermal Management Systems

Sidney Baltzer Thomas Lichius Jörg Gissing Peter Jeck Lutz Eckstein
Institute for Automotive Engineering (ika) – RWTH Aachen University
Steinbachstraße 7, 52074 Aachen
baltzer@ika.rwth-aachen.de

Jörg Küfen
Forschungsgesellschaft Kraftfahrwesen mbH
Steinbachstraße 7, 52074 Aachen
kuefen@fka.de

Abstract

Due to the higher complexity of electrified vehicles the requirements for vehicle components and vehicle design augment and new development tools are desirable. The following paper describes the design of a hardware-in-the-loop test bench along with its structure using Modelica and a Remote Process Communication library. The aim is to support the development of components and operational strategies under realistic boundary conditions illustrated by the example of a waste heat recovery system. The test bench is planned and built up within the scope of the public founded project qOpt at the Institute for Automotive Engineering (RWTH Aachen University) in cooperation with the Forschungsgesellschaft Kraftfahrwesen mbH Aachen and the Institute of Automatic Control (RWTH Aachen University).

Keywords: hardware-in-the-loop simulation, thermal management; vehicle simulation; combined heat and power generation, waste heat recovery, electric vehicle, Plug-in hybrid vehicle, thermal storage

1 Introduction

A pursued objective of politics and industry is to improve the efficiency and reduce the emission of individual mobility. For achieving that, the electrification of the drive train seems to be a promising approach. The wide distribution of purely electric vehicles lacks due to their short driving ranges since the specific energy content of current traction battery systems is rather low which leads to a high vehicle

weight. Besides, the costs for such systems are still quite high. Plug-in hybrid electric vehicles (PHEV) or range extended electric vehicle (REEV) provide the opportunity to combine the advantages of a conventionally propelled vehicle such as their high driving ranges with the possibility of driving electrically and thus without emissions. To increase the electric driving range an efficient treatment of the electric energy is obligatory. This includes the optimization of the drive train, the reduction of the electric energy demand for auxiliary consumers for example by means of an intelligent thermal management. In order to exploit the maximum potential of such a drive train a complex operational strategy in consideration of all energy forms has to be provided. For example in the scope of the public founded project qOpt, which enables this research, especially the reduction of auxiliary electric heaters during the winter term is focused. Therefore a waste heat recovery system in form of a latent heat storage in combination with an operational strategy will be developed.

For an a priori design the requirements for new simulation tools augment. But often not every component may be simulated properly so hardware tests are still necessary. A combination of simulation models and specific hardware components in a hardware-in-the-loop (HIL) environment provides the possibility to reduce building up physical prototypes for a high number of variations.

HIL systems are widely used for control systems, like engine control units. An extension of such systems for prototyping components is the logical consequence and is to be considered further on in this paper.

2 Hardware-in-the-Loop System

In general, HIL simulation systems provide the opportunity for the following three points:

- Component tests and component design
- Design, test and validation of operational strategies
- Control of test bench components

Such a system is built up at the Institute for Automotive Engineering (ika), RWTH Aachen University, in cooperation with the Forschungsgesellschaft Kraftfahrwesen mbH Aachen (fka).

The main system consists of the simulation environment, the test bench components and its controls and the data exchange process. All three systems are explained further in the following sub chapters.

2.1 Holistic Model Library

For the mentioned reasons a holistic model library has been developed at the ika in cooperation with the fka and is constantly increased and improved [1].

The library contains different kinds of vehicle models, including their drive train, passenger cabin, and their respective cooling circuits. Also building systems may be considered, to solve future problem issues like vehicle-to-home (V2H) or vehicle-to-grid (V2G) applications. All models can be controlled and evaluated under different dynamic boundary conditions (e.g. drive cycles, ambient conditions) (cf. Fig. 1).

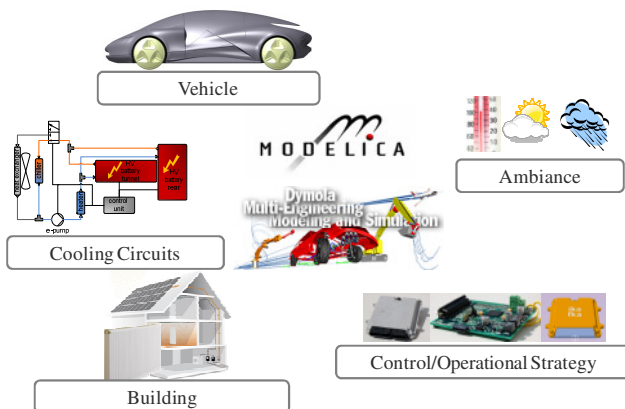

Fig. 1: Holistic simulation approach

The library is implemented following an approach of high scalability and modularity, so the level of detail may be adjusted depending on the issue to be investigated (cf. [1]).

2.2 Thermo-hydraulic test bench

The common interfaces for thermo-hydraulic simulations are the temperature, volume flow rate and the pressure. When emulating physical systems in a simulation environment the respective physical values have to be provided with a thermo-hydraulic test bench at every time step. The used test bench for the HIL system is shown in Fig. 2. For the hydraulic part, a controllable fluid pump and several controllable valves are integrated to adjust the volume flow rate and the relative pressure at the device under test (DUT).

The temperature is regulated with a heating device and a fluid cooling system. When connecting a refrigerant system also temperatures less than ambient temperature can be achieved.

The test bench is operated by a CompactRIO system. Since the system is not hardly real time capable with bigger models also a PXI System may be connected, which is presented in [3].

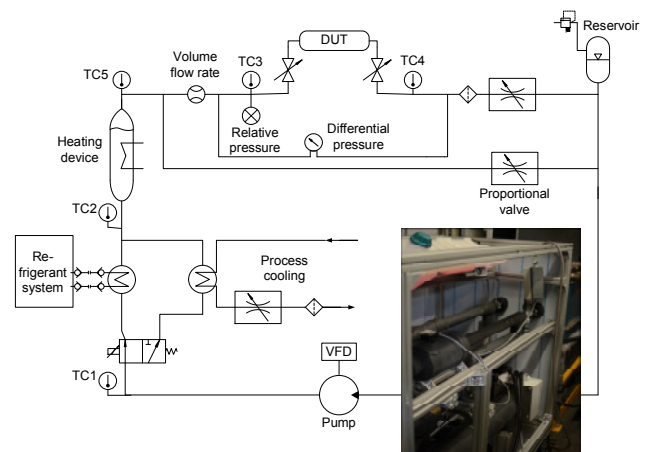

Fig. 2: Thermo-hydraulic test bench

2.3 Data Exchange Process

The software configuration of the HIL consists of several applications, which are simultaneously working together. The participating applications address different concerns at the HIL, e.g. simulation and test bench control.

Proper execution and interaction of all applications need to be assured. Thereby the resulting challenge for the HIL system is the elimination of unwanted side effects between the applications in order to avoid mutual interference of the applications during operation.

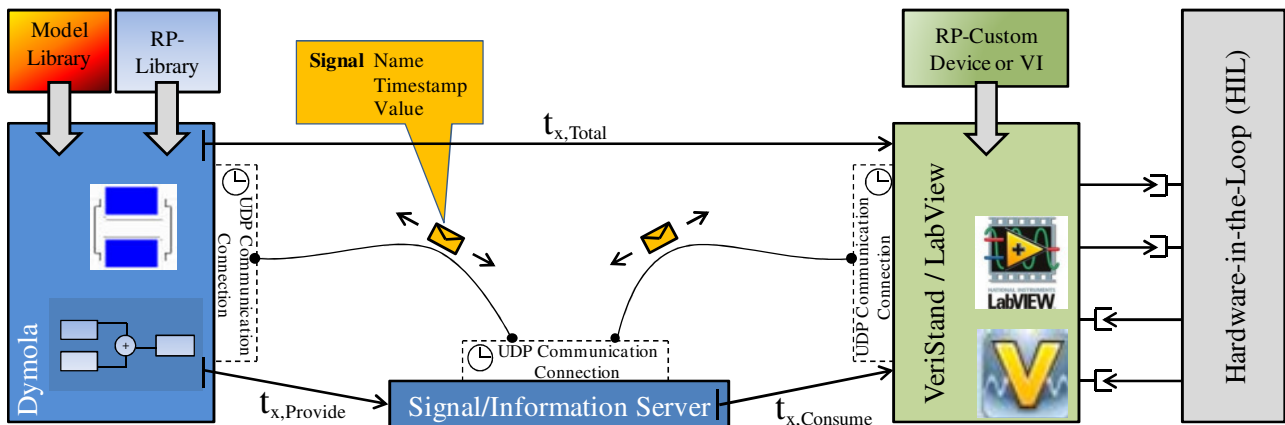

Fig. 3: Software structure of the HIL system. Multiple applications are joined for operation.

An overview of the participated applications currently in use at the HIL is shown in Fig. 3. Most important are Dymola and LabView. Dymola is responsible for hosting the physical model of the surrounding environment, which generates control requests for the test bench and the DUT. The management of the HIL system itself is based on National Instruments LabView [6] in optional combination with VeriStand [7], executed on a CompactRIO hardware and a Windows based personal computer. The CompactRIO executes all requests coming from the physical model output. LabView in combination with the CompactRIO ensures reliable control of the hardware of the test bench and keeps the test bench within applicable operating conditions.

At the same time LabView and the CompactRIO capture measurement data from test bench and DUT and return these back to the physical simulation in the Dymola environment. As Dymola is normally not targeted for real-time interaction with control components, new coupling features have been integrated to Dymola in order to implement the previously mentioned linkage of applications.

The connection between the applications is realized by an additional Remote Process Communication (RPCom) interface library, developed at fka. The library provides communication and synchronization elements, which are added to the physical model in Dymola in order to build an externally accessible interface with input and output data (cf. Fig. 4). This interface is accessible while the simulation is running. Corresponding elements of the RPCom Library are as well integrated in a LabView VI¹ or in VeriStand using a RPCom Custom Device [8].

¹ Individual, decoupled operation of all applications can be performed even if the RPCom elements have been integrated, allowing enhancements of the physical model and the test bench in parallel without removing the RPCom elements.

The RPCom library is implemented in .NET and embedded by Dymola using a system native c wrapper [5]. To allow access to the .NET components by the system native functions called by Dymola the intermediate code is modified such that all managed code elements are exported with system native interfaces [9]. The RPCom functionality can be used to even extend the co-operation of tools at the HIL to further applications, like e.g. a driving simulator, if these are required.

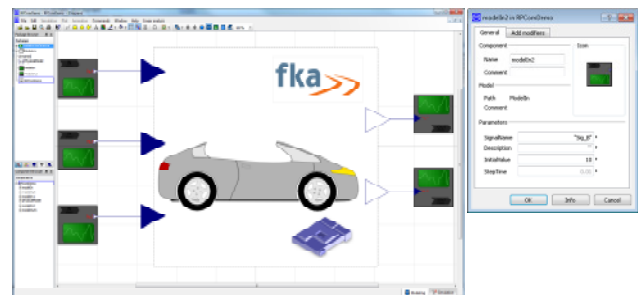

Fig. 4: Simple physical model in Dymola with additional RPCom elements

Main responsibility of the RPCom library is binding the individual applications together by organizing a coordinated signal exchange. This is realized by the RPCom library using UDP communication making distributed execution of all applications on a multi-computer network possible, completely decoupling the control of the test bench hardware from the simulation itself. Supplementary to data exchange, a synchronization functionality for all applications, necessary to make the operations of simulation and test bench behaviors coherent, is taken out by the RPCom library.

The exchange of signals between the applications is organized by symbolic IDs. Finally this means that all signals are managed within a signal pool by a unique symbolic name, which is associated with in-

formation on the corresponding value along with a the timestamp of last known validity of the value and supplementary meta-data, like physical unit or a detailed signal description. Currently, all elementary data types, such as double, integer or boolean values are supported. Vectors shall be supported in a future extension of RCom.

All signals are initially stored in local caches assigned to each participating application. In regular, configurable cycles - which depend on the timing requirements - these caches are synchronized. The synchronization can be selected to match the individual timing requirements of the application, avoiding unnecessary data exchanges. Altogether the synchronized signal caches of the applications build up a distributed information server.

For reliable HIL operation, the connection of applications and the timing behavior realizable by the RCom library are relevant in order to ensure deterministic HIL operations.

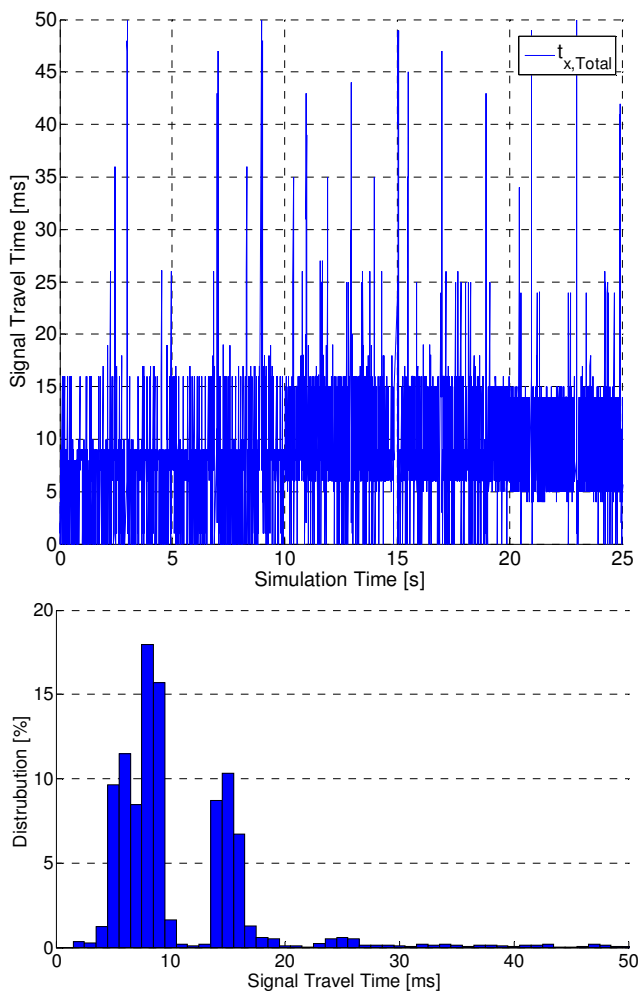

Fig. 5: Signal travel time ($t_{x,Total}$) and distribution measured during HIL operation for exchanged data between the coupled applications. Configured cycle time is 10 ms.

Due to the systems thermal inertia, soft hardware requirements can be applied for the cooperation.

Fig. 5 shows a timing measurement executed on the HIL system with a configured synchronization time of the application caches of 10 ms by the RCom library. In the analyzed scenario Dymola and LabView are operated on the same machine. A pool of 25 signals is exchanged between the applications. The cycle time of the Dymola Model is 100 ms while HIL cycle time for test bench control is set to 10 ms. As the measurements in Fig. 5 implies, the exchange rate is very stable around 10 to 20 ms.

The benefit of the integration of the RCom library is to distribute different HIL concerns to multiple computer systems within a network, e.g. decoupling hard real-time from weak real-time requirements. Also an easy partitioning of different Dymola model segments to more than one computer system can be realized, allowing integration of even complex and computation time intensive model configurations. Both benefits are utilized within the HIL system.

3 Augmented CHP usage of the internal combustion engine in electrified vehicles

Especially in winter terms the thermal management of electrified vehicles represents a major challenge. A temperature sensible component e.g. the traction battery needs to be conditioned and heating energy has to be provided for the passenger cabin. When driving purely electrically the heating energy has to be supported electrically which directly affects the electric driving range. Thus, waste heat recovery is a promising approach.

In the scope of the project qOpt the electrified vehicle Opel Corsa Hybrid 3 (cf. [2]) of ika is converted to a Plug-in-hybrid electric vehicle. Besides, an optimization of the thermal management of the vehicle is considered. In this article the potential of the integration of a thermal storage into a PHEV to enhance the electric driving range is further analyzed by means of hardware-in-the-loop simulations.

3.1 System architecture

The vehicle data including the passenger's cabin are listed in Tab. 1. Since the internal combustion engine (ICE) has a high potential for waste heat re-

covery, the ICE and its cooling circuit is considered as the device under test (DUT).

Opel Corsa Hybrid	
empty weight	1150 kg
power (ICE)	44 kW
power (electric machine)	37 kW
battery capacity	16 kWh
cabin volume	3 m ³
window surface	2 m ²

Tab. 1: Vehicle data of the Opel Corsa Hybrid 3

In Fig. 6 the schematic hardware setup is shown. An additional heat exchanger (HEX) is integrated into the cooling circuit of the ICE to provide the possibility to warm up the ICE or use its waste heat. The heat exchanger is the interface between both the electrified vehicle and the HIL system. Since the integrated pump is belt driven, an additional electric pump is integrated to achieve higher volume flow rates when driving at low engine speed or when driving purely electrically. Furthermore to monitor and control the cooling circuit, different sensors for volume flow rate, relative pressure and temperatures are integrated.

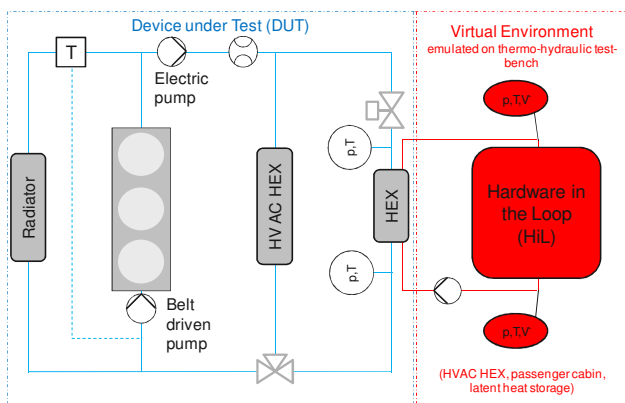

Fig. 6: Schematic view of the HIL setup and its connection to the cooling circuit of the internal combustion engine

To analyze the waste heat at different driving cycles, the vehicle is placed on a dynamic chassis dynamometer. The driving resistance for the specific Opel Corsa are adjusted, so a realistic power output is achieved. The current test setup is shown in Fig. 7. As mentioned above a winter term scenario and the possibility of waste heat recovery is analyzed. But since with this setup the winter term boundary conditions can only be adjusted to the ICE it is necessary to simulate the remaining vehicle components. For

this purpose inter alia the library mentioned in chapter 2 is used.

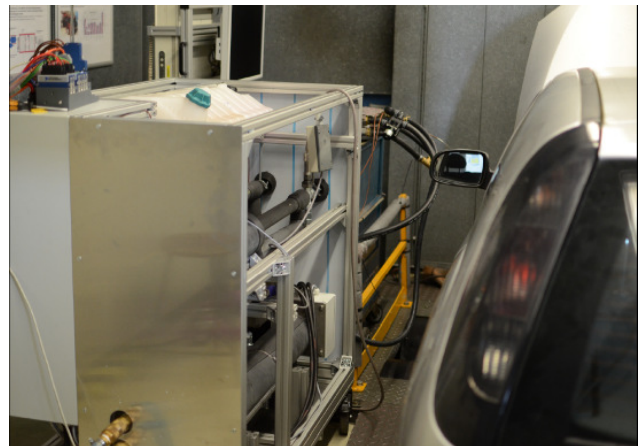

Fig. 7: System setup with the Opel Corsa on the dynamic chassis dynamometer connected to the HIL test bench

3.2 Simulation models

In the application case all thermal energy sinks are modeled in Dymola/Modelica. This includes the model of the passenger cabin and the HVAC unit. Besides, a thermal storage is considered. The heat exchanger of the HVAC uses the measured temperature to calculate the heat flow rate into the cabin. The heating demand is determined by the passenger cabin model. It includes the different convective and radiative heat flow rates to and from the environment (cf. Fig. 8 and [4]). Inside the heating circuit an additional electric heater is installed to provide heating energy when the vehicle is driven purely electrically.

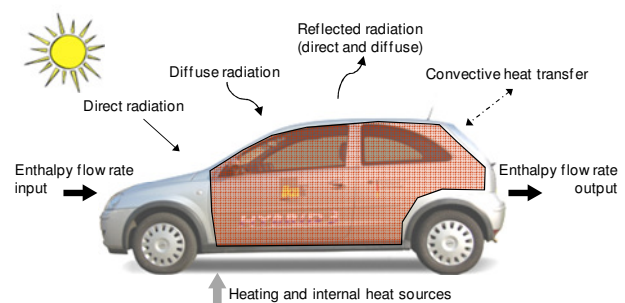

Fig. 8: Energy flows in passenger's cabin model

In this application example a latent heat storage was chosen. It is modeled according to [10]. The latent material has a melting temperature of about 65°C. Depending on the temperature gradient between the cooling fluid and the latent material the thermal conductance is calculated.

3.3 Scenario and boundary conditions

To analyze the benefit of an advanced combined heat and power (CHP) usage of the ICE (engine data cf. Tab. 1) a realistic scenario is defined. A drive cycle with a highway part and a rural part is used for the simulations. On the highway the vehicle is propelled by the internal combustion engine at a constant speed of 110 km/h. The waste heat is used to warm up the ICE and to provide heat for the passenger's cabin. Shortly before the thermostatic valve opens (engine is warmed up) a valve is operated, opening the bypass to the thermal storage. In this way an advanced combined heat and power generation usage of the ICE is achieved since the opening time of the thermostatic valve is minimized. Thus, less heat is rejected to the environment and a higher amount of waste heat is used. As mentioned before, all heat sinks are simulated in Modelica and the respective heat flows rates are transferred from the engine's cooling circuit in the thermo-hydraulic test bench.

Subsequently, the vehicle enters a rural zone (Urban part of HYZEM cycle) and is operated purely electrically. The stored energy from the thermal storage is then used for providing heating energy for the passenger's cabin, so the high value electric energy need not to be used for heating purposes.

As ambient conditions a typical winter scenario is chosen (0°C ambient temperature, 100 W/m² solar radiation) (cf. [11]).

4 Results

In Fig. 9 the dynamic profile of the engine cooling temperatures before and after the heat exchanger that is connected to the HIL are shown (cf. Fig. 6).

The initial temperature of the engine is 10 °C. The waste heat of the ICE warms up the engine and by the means of the heat exchanger in the HVAC the passenger cabin. At the beginning only little heating energy is transferred through the HVAC heat exchanger because of the low temperature gradient. At a temperature of 84 °C in the ICE cooling circuit the valve, to regulate the volumetric flow through the thermal storage is opened. Due to the high temperature gradient a high amount of heat is transferred to the thermal storage. The measurement clearly shows this point. Both the temperature before and after the heat exchanger are reduced. Subsequently the temperature gradient and therefore the heat flow rate into the storage decreases (cf. Fig. 9).

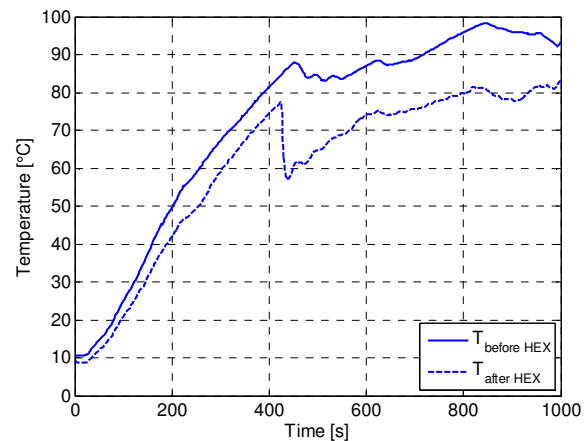

Fig. 9: Engine cooling temperatures before and after heat exchanger (cf. Fig. 6)

Fig. 10 shows the dynamic curve of the heat flow rate to the cabin and to the storage. Within the first 300 seconds the heating power increases since the engine cooling temperature increases. After that the control unit for cabin heating demands a lower heating power to maintain comfort temperature (cf.[4]).

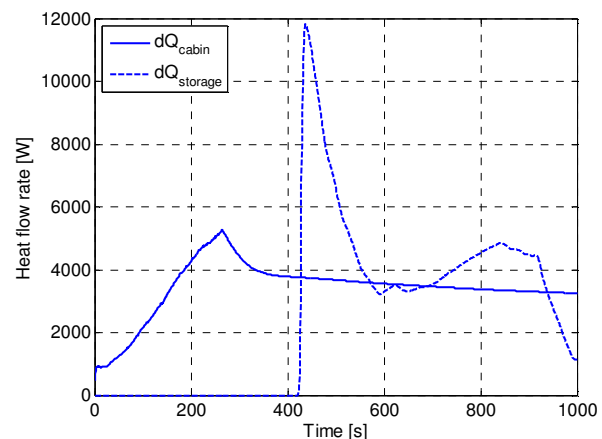

Fig. 10: Heat flow rates for the passenger's cabin heating and to the PCM storage (cf. Fig. 6)

In Fig. 11 the temperature curve of the thermal heat storage is shown. The melting point of the latent material is clearly stated out. At the end of the ride the thermal storage reaches a temperature of about 85 °C. The contented energy amounts about 700 Wh.

During the subsequent purely electric ride the heating energy may be used for cabin heating and by this the heating demand for the next 600 seconds may be provided nearly completely by the stored waste heat of the combustion engine. Thus, the electric driving range can be enhanced by about 4 km.

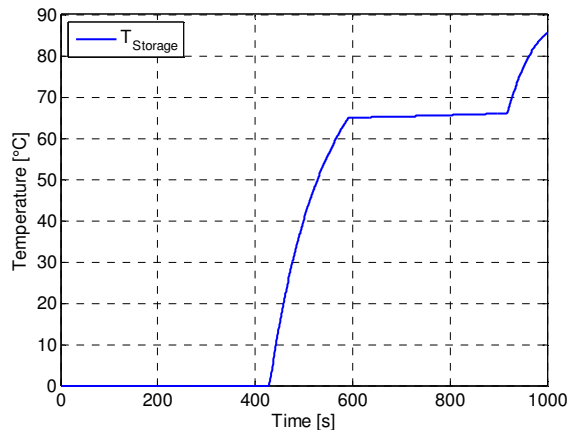

Fig. 11: time dependent temperature curve of the latent heat storage

5 Conclusion and Outlook

Due to the higher complexity of electrified vehicles the requirements for vehicle components and vehicle design augment and new development tools are desirable. In this article a HIL system using Modelica and an UDP interface has been presented which was developed at the Institute for Automotive Engineering (ika), RWTH Aachen University, in cooperation with the Forschungsgesellschaft Kraftfahrwesen mbH Aachen (fka). The connection between the applications is realized by an additional Remote Process Communication (RPCom) interface library, developed at fka.

Performance tests show that the connection of applications and the timing behavior is reliable to ensure deterministic HIL operations, at least for low real time requirements. Besides, by this data exchange progress it is possible to separate the simulation and the test bench control hardware, especially when models with a higher complexity demand high performance hardware.

An application example was given in which the potential of integrating a thermal heat storage unit into the cooling circuit of the ICE of a PHEV was investigated by means of HIL simulation. In order to measure the usable amount of waste heat of the ICE the vehicle was placed on a dynamic chassis dynamometer. All heat sinks, like the passenger cabin as well as the thermal storage were simulated in Dymola and the respective physical values were transferred to the thermo-hydraulic test bench. The results show that a reasonable amount of waste heat could be recovered in a thermal storage. Therefore, the electric driving range can be enhanced by provid-

ing the heat energy of the passenger cabin by the thermal storage unit.

The HIL system will be used further in the project qOpt to develop an operational strategy in consideration of the heat demand for electrified vehicles taking into account a latent heat storage system. Besides, in another project an electrical and thermal coupling between vehicles and buildings will be investigated further on.

6 Acknowledgement

The authors would like to thank the State of North Rhine-Westphalia/EFRE for their financial support in the research project qOpt.

References

- [1] Bouvy C., Baltzer S., Jeck P., Lichius T., Gissing J., Eckstein L.: Holistic Vehicle Simulation using Modelica - An Application on Thermal Management and Operational Strategy for Electrified Vehicles. In: Proceedings of the 9th Modelica Conference 2012, Oberpfaffenhofen, Germany, Modelica Association, 3-5 September 2012.
- [2] Biermann J.-W., Gnörich B.: From Micro to Full Hybrid - Two cars developed by fka and ika. In: International Automotive Congress 2008, Shenyang, China, 31 October 2008.
- [3] Baltzer S., Lichius T., Gissing J., Jeck P., Küfen J., Barkow A., Eckstein L.: Hardware-in-the-Loop-Prüfstand zur Auslegung von Thermomanagementsystemen im PKW. In: Virtuelle Instrumente in der Praxis 2013. Mess-, Steuer-, Regel- und Embedded-Systeme - Begleitband zum 18. VIP-Kongress, Germany, 2013.
- [4] Bouvy C., Gissing J., Lichius T.: Kühlsystementwicklung und Wärmemanagement für PlugIn-Hybridfahrzeuge. In: Proceedings of the E-MOTIVE Expertenforum „Elektrische Fahrzeugantriebe“, Aachen, Germany, 7-8 September 2011.
- [5] Modelica Association (2013): Modelica Language Specification 3.2, www.modelica.org.
- [6] National Instruments Labview, User Manual www.labview.com.
- [7] National Instruments Veristand, User Manual www.veristand.com.
- [8] National Instruments – Customizing the NI VeriStand Engine, NI Whitepaper 12640, 9th August 2013. www.ni.com.

- [9] Daskin D. - Simple Method of DLL Export without C++/CLI, CodeProject 27th June 2009. www.codeproject.com.
- [10] Mehling H., Cabeza L. F.: Heat and cold storage with PCM. An up to date introduction into basics and applications. Berlin, Germany, 2008.
- [11] Strupp N. C., Lemke N.,: Klimatische Daten und Pkw-Nutzung: Klimadaten und Nutzungsverhalten zu Auslegung, Versuch und Simulation an Kraftfahrzeug-Kälte-/Heizanlagen in Europa, USA, China und Indien. Frankfurt a. Main, Germany, 2009.