

# Modelica for large scale aircraft electrical network V&V

Martin R. Kuhn Yang Ji

German Aerospace Center (DLR), Institute of System Dynamics and Control

Münchnerstr. 20, 82234 Weßling

martin.kuhn@dlr.de yang.ji@dlr.de

## Abstract

More electrically powered aircraft reveals some significant advantages such as weight decrease, reduced maintenance requirements and increased reliability and passenger comfort. However, the development of the future more-electric aircraft (MEA) systems is a very challenging task. Its complexity may be handled by a model supported design approach for the total aircraft design process. A key factor of applying model based design is dedicated modeling and simulation techniques for all design phases. The highest complexity can be seen in the systems validation and verification phase where the aircraft system is integrated from the supplier's models.

While the capability to conveniently model complex physical systems with Modelica is generally accepted, the capability to perform large scale model integration and analysis as part of a validation and verification process remained unproven. In this paper we give evidence of Modelica/Dymola to be suitable for the virtual testing of complex energy systems in the future MEA design process. We demonstrate the modeling and the simulation results of component stand-alone tests as well as the tests of an integrated aircraft power network.

*Keywords:* V&V; electrical network; simulation; aircraft

## 1 Introduction

The model based design approach is a key factor for more efficient aircraft design with its growing demand to optimize the complex physical systems containing mechanical, electrical, hydraulic, thermal, control, electric power or process-oriented sub components [15]. Especially the more electric aircraft concept relies on incorporating high quality system models in the complete aircraft design process [1]. The process itself briefly can be divided into 4 major phases: con-

cept phase, system specification phase, system development phase and system verification phase [5].

- **Concept phase:** During concept phase a two-fold iterative optimization is performed on aircraft manufacturer side. This includes aircraft concept and global energy system architecture optimization.
- **System specification phase:** In this phase, a frozen energy system concept is provided by the aircraft manufacturer. Additionally, more detailed aircraft data about structure, cabin, light physics, engine and electrical power generation are available. The selected system suppliers conduct full concept definition where all the requirements and risks are understood. The aircraft manufacturer's requirements is transformed to the level of equipment suppliers by the system suppliers. Stability studies and failure analysis of aircraft electrical network are typical activities during the system specification phase.
- **System development phase:** In this phase preliminary and detailed design of equipment takes place. Verification and validation for artifacts are done, which are produced during this phase.
- **System verification phase:** The objective in the system verification phase is to demonstrate the maturity of the systems in a realistic integration and verification of more-electric aircraft systems, capable of covering all phases of the development process. The virtual integration platform for energy systems allows addressing integration issues prior to their physical integration on the test rigs and also extend test coverage. Power quality investigation of the integrated network will be of the interest in this phase. The typical tasks of the aircraft manufacturer in this phase are: monitor supplier system development by verification of system performance and functions, integrate sys-

tems in physical and functional aircraft, verify integrated systems and validate simulation models versus test results.

The model types and level of detail change for every phase. For example an advanced concept phase tool like ENADOT [14], applicable for optimal architecture design of the electrical energy system, in general does not demand more detailed electrical circuits than resistive elements. In contrast, the aircraft electrical network validation and verification process strongly relies on software for detailed and numerical complex modeling, simulation and analysis of network components and systems. Substantial efforts were made to reach platform independence and link simulation tools each with special strengths and dedicated for specific domains. Especially the FMI standard was a major step forward and was verified to improve an aircraft systems design process. Nevertheless, for the sake of performance and transparency, industrial processes often rely on a single common tool.

The software used in an aircraft project for the systems integration validation and verification (V&V) process is defined by the airframer for all model suppliers and contributors. While Modelica has found attraction in the automotive sector, it is not the standard for detailed simulation in aeronautic industry yet. Inspired by the success in the prior design phases, a study was performed in the context of the CleanSky project [4] to evaluate the potential and performance of Modelica and the commercial tool Dymola for electrical V&V. In this paper we give an overview of the necessities of the infrastructure which had to be developed. Necessary tools are addressed and lessons learned from the study are documented. It is the aim of this paper to rise awareness of the needs to conduct V&V studies. This paper quotes parts of [7, 6] with special focus on the Modelica community.

In chapter 2 the general procedure for model V&V is presented. The following paragraph gives an overview of the models and library structure. Some results and lessons learned from simulation are documented in the “simulation” chapter. It is concluded by an overview of the methods and tools developed for the study.

## 2 Procedure of virtual testing

In this chapter we want to reveal the general procedure of the V&V process. Details were published in [7].

Today, virtual testing of the integrated aircraft energy system is becoming an indispensable task in the

system verification design phase. The virtual testing procedure enables integration of the system by software before the real physical integration on the test rigs and extends test coverage. The behavior of the integrated system is estimated to be representative since component models are verified by in-house hardware tests at the suppliers. Each component is delivered as detailed (behavioural) and abstracted (functional) model.

The virtual testing process can be briefly divided into two steps. First, each subsystem or component model shall be tested for correct operation by so-called component standalone tests. A standalone test usually consists of a bunch of single tests such as power connection, power disconnection, power consumption at steady state, current harmonic analysis and so on, for one component. Standalone tests are required for both functional and behavioral models.

Once standalone tests for all components and subsystems are successful finished, in the next step simulations and tests of the total integrated system model are performed. Finally, specific analysis and post-treatment tasks can be performed based on the simulation results of the integrated models.

## 3 Modeling

To illustrate the type of system under investigation, a typical MEA energy system is depicted in figure 1. The system is powered by the variable frequency generator which controls the bus voltage by the generator control unit (GCU). The AC voltage is rectified by an auto transformer rectifier unit (ATRU) which feeds the environmental control system (ECS), DC loads and the direct current charging unit (DCCU) connecting low voltage DC loads. Low level AC voltage loads are supplied by an auto transformer unit (ATU).

### 3.1 Functional/behavioural model

As written before, different modeling levels apply for different test scenarios. Today, aircraft industry utilizes a three multi-level approach for the design of the aircraft system [10].<sup>1</sup>

The models are split into three types:

<sup>1</sup>To improve the international common understanding of modeling levels and modeling needs, SAE Aerospace organisation will publish a document titled “AIRCRAFT ELECTRICAL POWER SYSTEMS. MODELLING AND SIMULATION. DEFINITIONS.” in the near future

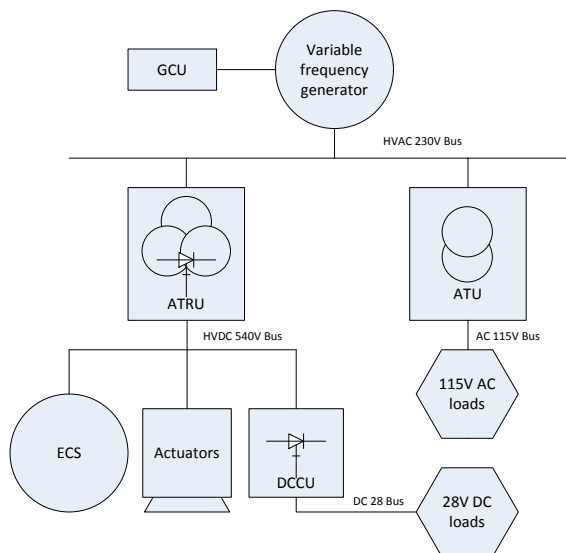

Figure 1: Electric network architectures for More Electric Aircraft

- Architectural models consist of algebraic equations and are used for steady-state power consumption calculations.
- Functional models reflect the low frequency behavior of the original system till around one third of the base grid frequency excluding switching ripples. Functional models are derived from behavioral models by state space time averaging of high frequency periodical switching waveforms. Typical applications are stability studies [12, 11] and control design. For the AC network in research often a dq equivalent network representation [9] is chosen. For an industrial project this might be further restricted to an equivalent one phase DC system. While this simplifies the system essentially by neglecting the AC phase information, no calculation of reactive power is possible.
- The behavioral models reflect both low and high frequency dynamics including switching effects. Behavioral models are based on equations derived from the subsystem structure and electrical circuit. The behavior at the terminals should be equivalent to the real hardware up to frequencies in the hundred kilohertz. Applications include power quality simulation and analysis of transient effects [8, 16].

The table 1 presents an overview of model requirements in all aircraft design phases.

For the system verification phase, functional models

are used for long term studies of the integrated system. Behavioral models are mainly used for detailed investigation of transients as power on phases.

### 3.2 Electrical components

The library of components and systems developed for the project can be seen in figure 2. The structure follows the needs of the V&V procedure: All models are implemented as a “behavioural” and “functional” representation.

All models have to be verified by associated standalone tests. The Modelica language concept showed to be beneficial in organizing integrated libraries with both, models and scripts. For example, in figure 2 the test routines for the 230VAC/115VAC auto-transformer rectifier model are emphasized. Scripts can contain procedures for parameter setting, simulation commands and post processing and documentation features. The newly developed scripts are addressed in chapter 5.3.

In the project it was confirmed, Modelica language and the Modelica standard library are capable of modeling all subsystems sufficiently. While the Modelica electrical library is known to be of limited size compared to design environments specialized for electrics, it was found out most components can be modeled by generic objects (e.g. rectifier unit) or they are very specific and need to be written textually by equations anyway (e.g. the generator). The only type of model which was missing showed to be a detailed magnetic hysteresis model. Magnetic hysteresis is of special importance for electrical power systems since the initial magnetizing effect of electrical transformers at power connection can lead to short-time excessive currents flowing into the transformer. This effect is called “inrush current” and investigated in [6]. The Modelica magnetic hysteresis model [17] was developed from JTI resources and will be part of the Modelica standard library in the future.

As an example for the library the ATU model is shown in figure 3 which is one of the critical magnetic elements. The component tests include harmonic current test, inrush current test, power connection and power disconnection test. The harmonic current analysis aims to determine disturbances due to the equipment on different frequency levels. Fast Fourier transformation (FFT) is performed after simulation of the ATU model reaches steady state condition (figure 4).

Design phase	Typical task	Required model
Concept	Architecture optimization	Level 1
System specification	Stability studies	Level 2/3
System development	Control design	Level 2/3
System verification	Virtual testing	Level 2/3

Table 1: Model requirements in different aircraft design phase

### 3.3 Integrated aircraft power system

The stand alone test are essential prerequisites to debug the single components for stable simulation before the integration. After successful stand-alone tests for all components, various scenarios for testing the complete electric power network can be performed. To demonstrate the capability of Modelica/Dymola to deal with large scale power systems, the proposed electric power network depicted in figure 5 has been simulated in Dymola at both behavioral and functional levels. The behavioral model is reduced by Dymola to a simulation model with 69 continuous time states. The linear system to be solved reduces to one equation system of order 18. The initialization system was reduced to five independent nonlinear equation systems where the largest was of order 33. While the numbers by itself seem not to be very impressive, complexity comes from the switching system.

In the demonstrated electric power network, the ATRU is connect to grid at 0.0025 second. After the pre-charging ATRU with 25e-3 second, the DC output of the ATRU is connected with the HVDC network. The PMSM which has a 20e-3 second pre-charging time is connected with the HVDC network at 0.055 second. After the power inverter in the PMSM is activated, a constant speed command is given for the PMSM under a constant load. AC currents and voltages of the VFG is recorded in the figure 6 for behavioral model and in figure 7 for the functional model. In the simulation results, it is clear to see the inrush currents at the moment of switching on ATRU and DC ripple at the ATRU output. These values are very important indicators for the stability study for the electric power network in MEA. [12]

## 4 Simulation and lessons learned

### 4.1 General

As benchmark of the study, the components and especially the large aircraft power systems had to be simulated to demonstrate the performance and robustness of Dymola's numerical solver for such a usually very

stiff power system and suffering from huge amount of event handling actions due to switching components.

In the study it could be demonstrated Modelica/Dymola is capable of simulating all component and integration tests. Compared to the traditional simulation platform for V&V tests, numerical speed showed to be excellent for the smaller component tests and competitive for the large integration test and might be further improved. Also it was detected, simulation speed is overwhelmingly dependent on the model quality and the experience of the designer. Stable and fast operation of the components with non-specialized integration algorithms as DASSL was almost mandatory for the successful large system integration.

From the example in the previous chapter it was seen, the complexity of the initialization in many cases prevents simulation already before start. As a workaround the designer may test initialization with the steady state option.

### 4.2 Identification of modeling errors

A typical problem for large scale simulation is abortion, slow progress of simulation or chattering caused by modeling problems. For a limited number of modeling errors, the simulator's log usually gives important hints while they are not easy to interpret. For example, in the V&V study dynamic state selection was indicated by the simulator for a (working) component model. For the large scale test this inhibited numerical problems. This phenomenon and a workaround for the magnetic system is documented in [ifeec]. As a second example, for the generator model standalone test algebraic loops were indicated in the simulator's log. Algebraic loops can occur for feedback loops with feedthrough part, which can not be simplified by the symbolic routines. While algebraic loops are unusual for standard electric circuits they appear easily for saturated elements. In the V&V study the equation system conditioned by the algebraic loop accounted for numerical problems. While it does not necessarily help, there is the option to cut the loop by insertion of a first order delaying element.

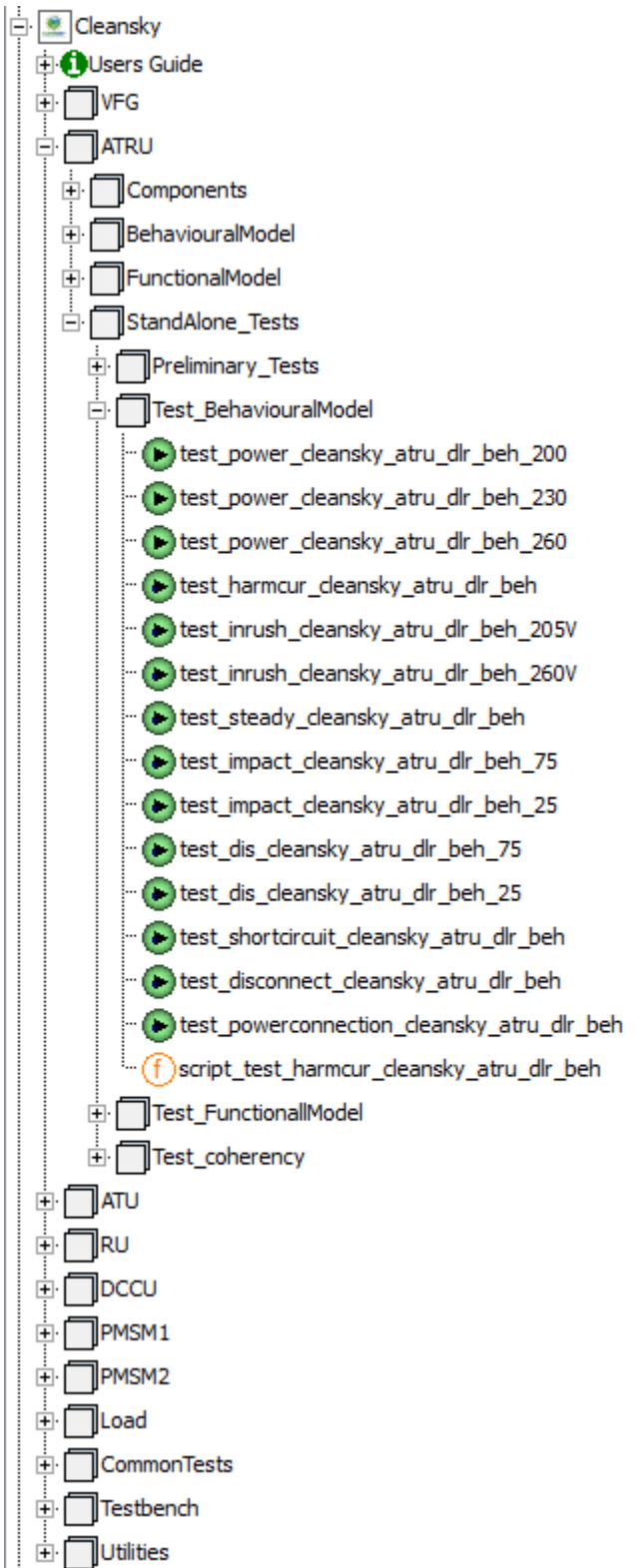

Figure 2: Library of the electrical system

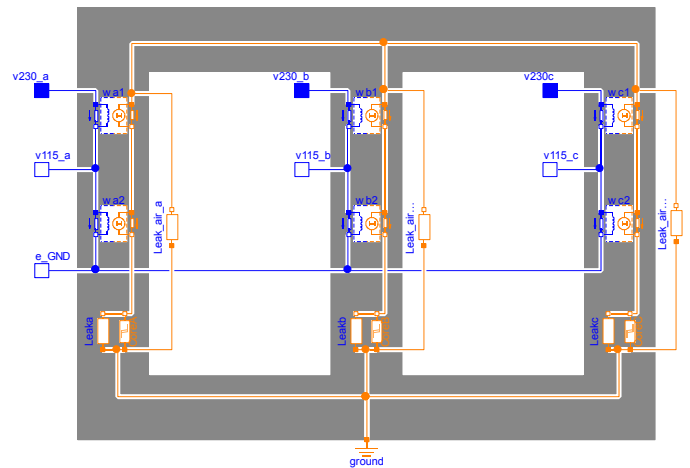

Figure 3: Modelica model of AC/AC auto-transformer

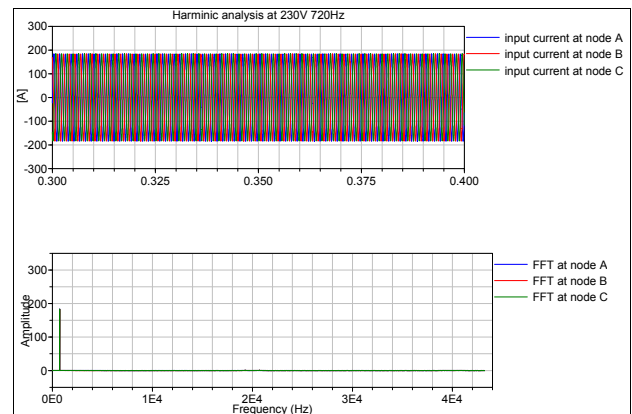

Figure 4: Current harmonic analysis of ATU at 230V and 720Hz input voltage

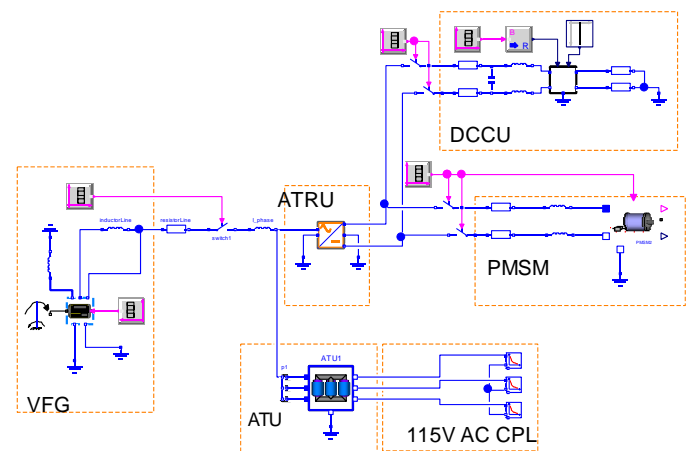

Figure 5: An integrated electric power network for MEA

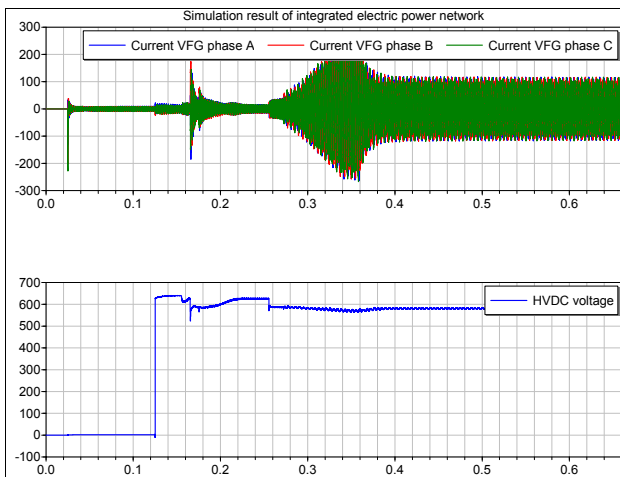

Figure 6: Simulation result of integrated electric power network: VFG current and HVDC voltage (behavioral level)

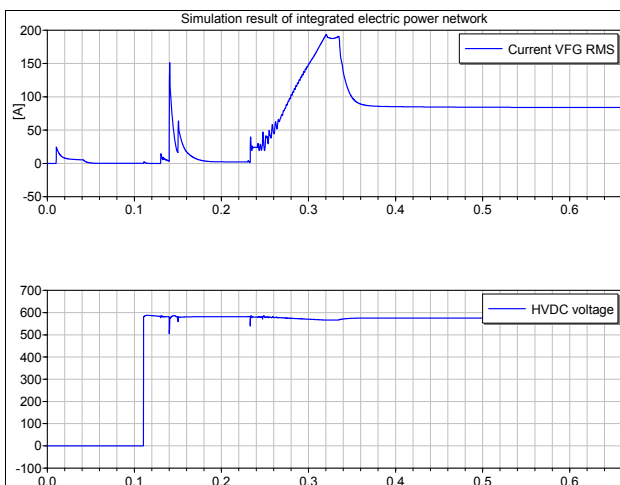

Figure 7: Simulation result of integrated electric power network: VFG current and HVDC voltage (functional level)

In practice the most common error is a stiffness of the equation system which can be traced back to modeling problems. Stiff means the eigenvalues of a linearized system have a real part which is negative and large in magnitude, compared to the reciprocal of the time span of interest [3, chapter 5]. For this problem usually no distinct warning is generated by the simulator. For small systems experienced designers may detect the sources of the problem by inspection. For larger systems built from verified components, new stability problems may arise while troubleshooting by inspection may fail due to the complexity.

The problem of modeling errors and its identification shall be illustrated via the circuit depicted in figure 8.

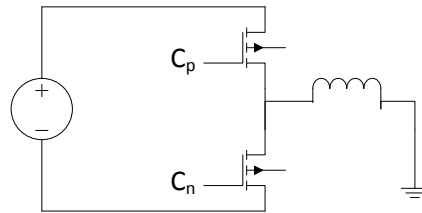

Figure 8: Example of switching circuit with inductance

The inductance on the right hand side is powered via the the transistors by positive or negative voltage. The most simple implementation of the transistor is a switching resistor with the levels high or low resistance, controlled by a Boolean input signal (e.g. Modelica.Electrical.Analog.Ideal.IdealClosingSwitch). For a pulse width modulation scheme, the inductor is powered by the upper or lower transistor where the control signal  $C_n$  is always the opposite of  $C_p$ . Since an overlapping operation of the transistors would result in a short circuit, for real systems the turn over of the complementary control signals includes a dead-time where both transistors are in high resistance mode. In simulation, a sudden interruption of the current path in the dead-time period results in a high voltage peak in the inductor due to  $v = Li$ . The inductor's flux vanishes slowly (stiff) due to the high switch resistances. This might sound like a simulation problem but in fact this is even a physical problem: For real transistors those voltages would also occur and could severely damage the semiconductor. This effect has to be prevented in design by a free wheeling diode or a "snubber circuit" in case of an inductive source. In the study this problem occurred for the motor inverter unit. As a counteraction the snubber circuit (a capacitance in parallel to the switch) was foreseen. While inserting tiny resistances/capacitances in the circuit is a well known but poor method to solve simulation problems, here the application adds physical meaning.

An other problem which can be related to physics is the "floating ground" problem. In the example, only the voltage difference of the voltage source is defined but the absolute levels of the connectors are calculated from the circuit. This may again result in chattering of the simulation if state variables are sensitive to this floating ground. The mathematical background of the problem is a ill-conditioned Eigenvalue vector and a high numeric sensitivity of the state. As in simulation "floating grounds" are problems of the real physical system as well which can lead to malfunctions of

the circuit. Both, circuit designer and model designer should be aware of it and should consider a direct connection to ground or a connection to ground via a large resistor. Floating ground problems often are shown in the simulator's translation log while the user may be overwhelmed by the amount of information at first.

For large systems there remains the problem of identification of the source of the stiffness. In the course of the study the following approach showed to be successful (Dymola specific):

1. DLR's Modelica Linear Systems 2 library is a very powerful tool to analyze a model. Since version 2013 its functions are embedded in Dymola's main window. The command "Full linear analysis" linearizes the system and gives the eigenvalues. A stiff system exhibits at least one large eigenvalue. The participation factors relate the states variables to the eigenvalues which identifies the critical components. In the example in figure 8, a large eigenvalue could be related to the inductor's state variable "current". The problem of the circuit can be detected by observing the current paths in the system.

Often the stiffness does not appear in the original system but in the course of the simulation. The "Full linear analysis" command can be invoked to linearize at a specified simulation time. For this, the next rules apply:

2. Simulation needs to start successfully. If the system does not initialize correctly a simulation from a no-load condition and successive connection of the loads may be successful. For Dymola, the "Dassl" solver generally shows a good compromise between accuracy and speed. For stiff systems there exist special solvers as "RadauIIa" (see [3, chapter 5] for example). In many cases the perpetual use of the solvers for stiff systems only conceals problems of the models which may return for slightly more complex systems. Nevertheless, for the identification of the problem it generally is a good idea to use a solver as "RadauIIa" to get the simulation running.
3. Simulation to the critical condition/time: The first step is to identify the critical condition by simulation. In many cases the critical time is the last successful simulation step. Then the "Full linear analysis" command is evoked with linearization at the critical time. Follow instructions 1..
4. If the simulation stops in the course of the simulation before an anticipated critical time or if no

evidence can be found at the last successful simulation step, a condition with similar critical conditions might be found in the earlier simulation. By observation of the "CPU time" (simulation time at each simulated time step) stiff conditions can be identified by steeper periods in the plot of the CPU time vs. simulated time.

## 5 New developments

In the course of the project, some deficiencies were identified for the implementation of the models and the automation of the results within a single environment. The following tools and scripts were newly developed to overcome the obstacles:

### 5.1 Signal processing tool

In an industrial design process, a tool chain must fulfill higher demands on automation, ergonomics and single tools are preferred than in usual research projects. Especially, tools for signal post operation are needed integrated in the design tool and must be scriptable. In JTI, Dymola was selected as single simulation platform and there was co-funding in the project MODELSSA to extend it by the necessary features. Amongst other features, a library of signal analysis methods in time domain (e.g. min/max, period, duty cycle, root-mean-square) and frequency domain (like FFT, IFFT, total harmonic distortion) was developed. All features are accessible graphically from the user interface and scriptable. The features are documented in [3] and were presented on the Modelica conference vendor sessions.

### 5.2 Modelling of magnetic hysteresis

For efficient modeling of magnetic circuits, the free Modelica.Magnetics.FluxTubes library [2] was applied for this study. The library is well established and was proven by hardware design studies. Material properties can be taken into account by linear and nonlinear permeability. As an important extension in the frame of the Cleansky project, DLR commissioned and supervised the development of magnetic hysteresis models for Modelica. As an outcome, a high fidelity model based on Preisach's equations was embedded (the original publication goes back to 1935, for implementation see [13] for example). For the study of inrush currents which was industrially motivated it was preferred to use another more efficient one. The so called "Tellinen hysteresis model" showed to



model the flux density  $B$  versus magnetic field strength  $H$  relationship of a measured ferromagnetic material well via moderate complex equations and thus by efficient simulation speed. Details and comparisons about the first release of the magnetic hysteresis models for Modelica were published in [17].

### 5.3 Dedicated scripting for tests

Most simulation tools provide basic post processing functions but with a limited perimeter. Thus, specific analysis functions usually have to be developed for the simulation platform using a post treatment language. Also systematic design and test automation often demands user specific scripts. When performing simple/single simulations, it is sufficient to select menu commands or to type commands in the command input line of the command window. But wanting to perform more complex actions as part of an industrial process (e.g. automatically repeat more complicated parameter studies a number of times) it is much more convenient to use the scripting facility. The goal is often to fully automate the simulation. Just to name some features, the script facility makes it possible to load model libraries, set parameters, set start values, simulate and plot variables.

Dymola supports easy handling of scripting, both with functions and script files (.mos files). Whether a function or a Modelica script file (.mos) should be used is up to the user, essentially the same functionality can be obtained with both. When a function should be the final result, a function is created, and the functionality is then created as an algorithm in this function using the Modelica Text layer of the function as an editor. When a Modelica script file (.mos) should be created, the command input line can be used for input, creating a command log that can be saved as a script. Scripts can be nested; functions can be nested and a Modelica script file may run other Modelica script files.

The test scripts were customized by DLR from existing commands of Modelica language and Dymola functions. The built in functions and model management tools of Dymola were found to be sufficient for the study. Among others, the following scripts and tools were found to be necessary repeatedly for the V&V study:

- Transformation of input data: From input files data are edited into a Modelica compatible type. This function is of major relevance in an industrial process since input data might not be Modelica compatible and use of additional software

is undesirable in standardized processes. By help of some Dymola built in functions conversions from text files, Microsoft Excel sheets and more was performed. Matlab's matrix data format .mat is supported immanent.

- Transformation of output data: Same as for the import, the output features are important. Typical outputs programmed in functions were time domain results (.mat result files), tables (Excel) and generic data (.txt). For generation of frequency domain data, it was necessary to have the Fast Fourier Transformation (FFT) function executable by script. Thanks to the co-funding by the JTI project this function is now provided in Dymola. Application of the FFT function include parameter studies with tabulated output of total harmonic distortion (THD) or harmonic content at specified harmonics.
- Coherency test models: Test of linear dependence of signals in time domain by convolution. Coherency is an important criterion in verification tests to analyze the validity of models and model abstraction levels. It is applied for verification of models versus hardware test data or between different models. The script calculates coherency by application of the coherency function to two simulation or measurement waveforms.
- AC modulation envelope: The AC envelope function is the smooth curve outlining the extreme positions of a distinctive alternating wave with a fixed frequency. The modulation envelope shows its amplitude variation in frequency domain. The AC amplitude is an important measure for the voltage quality which must be stabilized by the generator control. The developed function relies on peak finding and transformation of data to frequency domain by FFT.

As an example of an integrated test, the Dymola script for the worst case study of sympathetic effect is presented in Fig. 9. This script function firstly simulates the test bench till 5.791 second and records the simulation result in a "end.txt" file. This result will be always defined as initial condition for the following 20 time simulations with different connecting time for ATU2. A real variable Tatu2 is defined to vary the connecting time of ATU2 and has a time step  $\varepsilon = 0.000125$  second for each simulation loop. Simulation setups such as used integrator, simulation time are also defined in the script function. Additional scripts have been made



for post-processing. It is a big advantage for users, that a complex test like analysis of sympathetic effect can be easily formulated with Dymola scripting language in a very compact manner.

```
function Script_Case1_with_simulation_paper
import Modelica.Utilities.Flies.*;

protected
  Real Tatu2 = 5.791;

algorithm

  //performe simulation till steady-state
  translateModel("Case1");
  simulateModel("Case1",
    stopTime=5.79,
    numberOfIntervals=0,
    method="Radau",
    resultFile="Case1");

  //backup dsfinal
  copy("dsfinal.txt","end.txt",true);

  //do parameter studies about
  //switch on time of ATU2 with
  //time step 0.000125s

  for i in 1:1:20 loop

    Tatu2 :=5.791 + i*0.000125;
    importInitial();
    simulateExtendedModel("Case1",
      startTime=5.79,
      stopTime=5.8,
      numberOfIntervals=0,
      method="Radau",
      resultFile="dres_"+String(i),
      initialNames={"Tatu2"},
      initialValues={Tatu2},
      finalNames={"Tatu2"});

    //re-initialization
    Files.copy("end.txt","dsfinal.txt",true);

  end for;
end Script_Case1_with_simulation_paper;
```

Figure 9: Scripting for the worst case study of sympathetic effect

## 6 Conclusion

By the study, the applicability of Modelica and Dymola for large scale testing of aircraft electrical systems in V&V studies was demonstrated successfully. All demands on new functionality, additional models and specialized scripts could be met within the project.

It could be detected the reliability of simulation highly depends on mature models. The developed library therefore is an important base for propagation to a Modelica based V&V process in aircraft electrical systems simulation. Further effort should be made for robust initialization of the simulation.

## Acknowledgment

The research leading to these results has received funding from the European Union's Seventh Framework Programme (FP7/2007-2013) for the Clean Sky Joint Technology Initiative under grant agreement no. CSJU-GAM-SGO-2008-001.

## References

- [1] J. Bals, Y. Ji, M. Kuhn, and C. Schallert. Model based design and integration of more electric aircraft system using modelica. *Moet Forum at European Power Electronics Conference and Exhibition*, 2009.
- [2] T. Bödrich and T. Roschke. A magnetic library for modelica. In *Proceedings of the 4th International Modelica Conference*, 2005.
- [3] Dymola. User manual volume 1. Technical report, Dassault Systèmes AB, 2013.
- [4] CleanSky project: Systems for Green Operation (SGO). <http://www.cleansky.eu/>.
- [5] T. Giese, D. Schlabe, R. Slate, M. Crespo, F. Tichy, and C. Baumann. Extended design office concept definition. *Cleansky WP2.1.1 deliverable*, 2010.
- [6] Y. Ji and M. R. Kuhn. Physical modeling and simulation of inrush current in power transformers of more electric aircraft. In *IEEE IFEEC conference*, 2013.
- [7] Y. Ji and M.R. Kuhn. Modeling and simulation of large scale power systems in more electric aircraft. In *IEEE 14th Workshop on Control and Modeling for Power Electronics (COMPEL)*, pages 1–6, 2013.
- [8] Y. Ji, A. Pfeiffer, and J. Bals. Optimization based steady-state analysis of switched power electronic systems. In *Control and Modeling for Power Electronics (COMPEL), 2010 IEEE 12th Workshop on*, pages 1–6, 2010.
- [9] Paul C. Krause, Oleg Wasynczuk, and Scott D. Sudhoff. *Analysis of electric machinery and drive systems*. Wiley-Interscience, Piscataway, New York, 2nd edition, 1998.

- [10] M. Kuhn and M. Otter. A multi level approach for aircraft electrical systems design. *6th International Modelica Conference*, 2008.
- [11] M.R. Kuhn, Y. Ji, H. D Joos, and J. Bals. An approach for stability analysis of nonlinear electrical network using antioptimization. In *Power Electronics Specialists Conference, 2008. PESC 2008. IEEE*, pages 3873–3879, 2008.
- [12] M.R. Kuhn, Y. Ji, and D. Schröder. Stability studies of critical dc power system component for more electric aircraft using  $\mu$  sensitivity. In *Control Automation, 2007. MED '07. Mediterranean Conference on*, pages 1–6, 2007.
- [13] I. D. Mayergoyz. *Mathematical Models of Hysteresis and Their Applications*. Elsevier, 2003.
- [14] C. Schallert. Inclusion of reliability and safety analysis methods in modelica. *8th International Modelica Conference*, 2011.
- [15] Daniel Schlabe, Michael Sielemann, Christian Schallert, Dirk Zimmer, Martin Kuhn, Yang Ji, and Johann Bals. Towards a model-based energy system designprocess. In *SAE Power Systems Conference 2012*, Oktober 2012.
- [16] Ji. Y, J. Bals, and A. Pfeiffer. Multi-level power quality assessment towards virtual testing of more electric aircraft. In *IPEC, 2010 Conference Proceedings*, pages 28–33, 2010.
- [17] J. Ziske and T Bödrich. Magnetic hysteresis models for modelica. *9th International Modelica Conference*, 2012.